

FEATURES

- 4.5~14V input voltage
- Output Voltage: 0.69V~5.5V
- Output Current up to 10A
- High Efficiency 95%
- Remote on/off control
- Over current /short-circuit protection
- Over-temperature protection
- Adjustable Under voltage Lockout (UVLO)
- High reliability: designed to meet 5 million hour MTBF
- Minimal space on PCB:
 - 22.10 mm x 15.7mm x 9.1mm or
 - 0.87 in x 0.62 in x 0.36 in
- Operating Temperature: -40°C to +85°C
- UL/IEC/EN60950 compliant
- RoHS Compliant available
- PoLA Pin Configuration

APPLICATIONS

- Workstations, servers
- Desktop computers
- DSP applications
- Distributed power architectures
- Telecommunications equipment
- Data communications equipment
- Wireless communications equipment

Description

The **PoLAMQ7250R** series Power Modules are non-isolated dc-dc converters that operate over a wide input voltage range of 4.5Vdc to 14Vdc and provide a precisely (2%) regulated dc output with industry standard pin configuration. The MQ7250R requires a single resistor to set the output voltage to any value over the range, 0.69V to 5.5V. The wide input voltage range makes the MQ7260R particularly suitable for advanced computing and server applications that use an unregulated 8~12V intermediate distribution bus. Additionally, the wide input voltage range increases design flexibility by supporting operation with tightly regulated 5V, 8V, or 12V intermediate bus architectures. The modules have a maximum output current rating of 10A at typical full-load efficiency over 93%.

The module incorporates a comprehensive list of features. Output over-current and over-temperature shutdown protects against most load faults. A differential remote sense ensures tight load regulation. An adjustable under-voltage lockout allows the turn-on voltage threshold to be customized. **EasyTrack™** sequencing is a popular feature that greatly simplifies the simultaneous power-up and power-down of multiple modules in a power system.

***** Typical Application Circuit *****

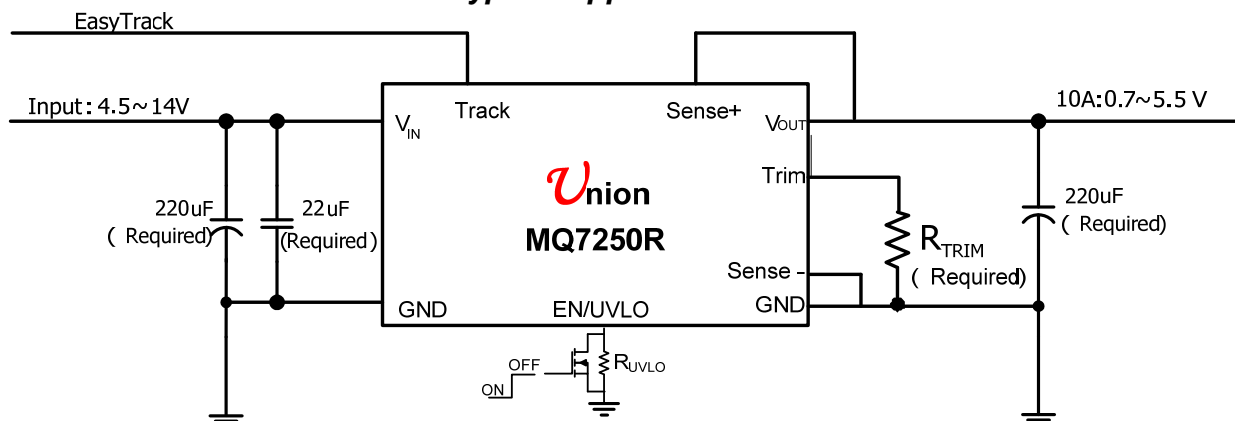

A. R_{TRIM} required to set the output voltage to a value higher than 0.69 V. See the Electrical Characteristics table.

B. If the Track pin is unused, this input should be connected to V_{IN} .

MQ7250R

Performance Specifications (at TA = +25°C)

Model	Input V _{IN} Range (V)	Output				Efficiency (%)
		I _{OUT} (A)	Trim Range (V)	Regulation		
				Line (%)	Load (%)	
MQ7250R	4.5~14	10	0.69 ~ 5.5	0.5	0.5	95

Mechanical Specifications

Dimensions are mm (inches)

<p style="text-align: center;">“T”</p>	Pin	Description
	1	N/A
	2	V _{in}
	3	GND
	4	GND
	5	V _{out}
	6	Sense+
	7	Sense-
	8	Trim
	9	N/A
	10	EasyTrack™
11	EN/UVLO	
<p style="text-align: center;">“S”</p>	Pin	Description
	1	N/A
	2	V _{in}
	3	GND
	4	GND
	5	V _{out}
	6	Sense+
	7	Sense-
	8	Trim
	9	N/A
	10	EasyTrack™
11	EN/UVLO	

Ordering Information

MQ7250R2T

Union Microsystems
Power module P/N

Input Voltage Range:
4.5~14V

T: Through hole
S: Surface Mount

Absolute Maximum Ratings

Note: These are stress ratings. Exposure of devices to any of these conditions may adversely affect long-term reliability. Proper operation under conditions other than those listed in the Performance Specifications Table is not implied.

Parameter	Symbol	Min	Max	Unit
Input Voltage	V_{IN}	-0.3	16	V
Storage Temperature	T_{STG}	-40	125	°C

MQ7250R Electrical Specifications: ($T_A=+25^{\circ}\text{C}$)

Parameter	Condition	Symbol	Min	Typ	Max	Unit
InputVoltageRange		V_{IN}	4.5		14	V
Output Current		I_o	0		10	A
Output Voltage Set point	100% load	ΔV_o	-2		+2	%
Temperature Regulation	$T_A = T_{A,MIN}$ To $T_{A,MAX}$	-		0.4		% $V_{O,SET}$
RemoteSenseRange					0.3	V
Line Regulation	See each output's corresponding character figure					
Load Regulation						
Output Ripple and Noise Voltage	$I_o=10A, 0\sim 20\text{MHz}$			1		% V_{out}
Transient Response	2.5 A/ μs load step 25% to 75% $I_{O,max}$, $V_o = 2.5\text{V}$	$C_o=220\mu\text{F}$	Recovery Time	150		μSec
			V_o Overshoot	100		mV

General Specifications

Parameter	Condition	Symbol	Min	Typ	Max	Unit
Maximum Capacitive Load	6A resistive load + Aluminum capacitor		220		10000	μF
	6A resistive load +Tantalum capacitor		220		10000	μF
Over current Protection				20		A
Output short-circuit current (average)	All				0.8	A
Under Voltage Lockout Trip Level	Rising and falling V_{IN} , 3% hysteresis			4.3		V
Start-up Time	10A resistive load, no external output capacitors			5		mS
Switching Frequency		F_o		300		KHz
Operating Temperature	Natural convection		-40		85	°C
Vibration	3 Axes, 5 Min Each	10~55Hz, 0.35mm, 5g				
	3 Axes, 6 Times Each	Peak Deviation 300g, Settling Time 6mS				
MTBF				5,000,000		Hour

Test Configurations

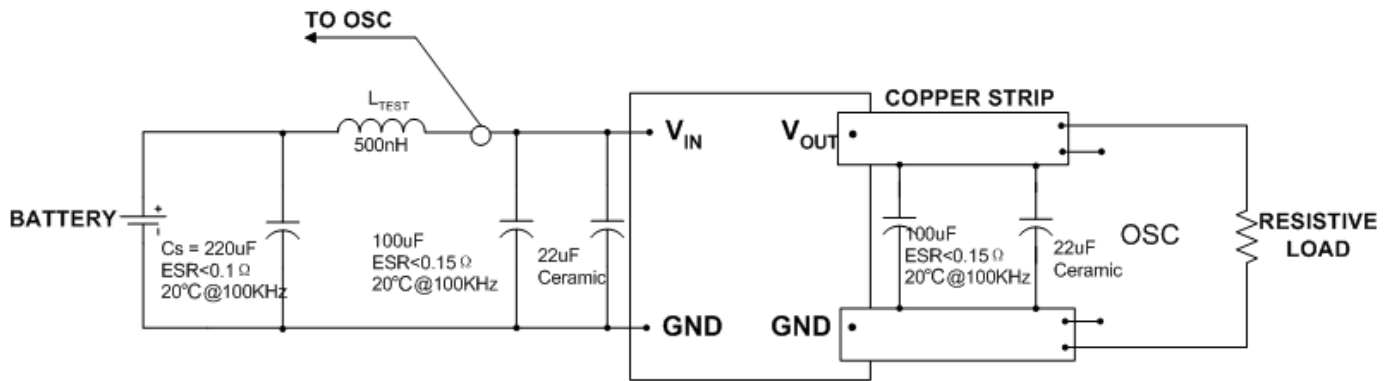

Fig 1 Test setup for input noise, output noise and ripple

Note:

Output noise is measured with 0.1µ F ceramic capacitor connected at the output. OSC measurement should be made using a BNC socket.

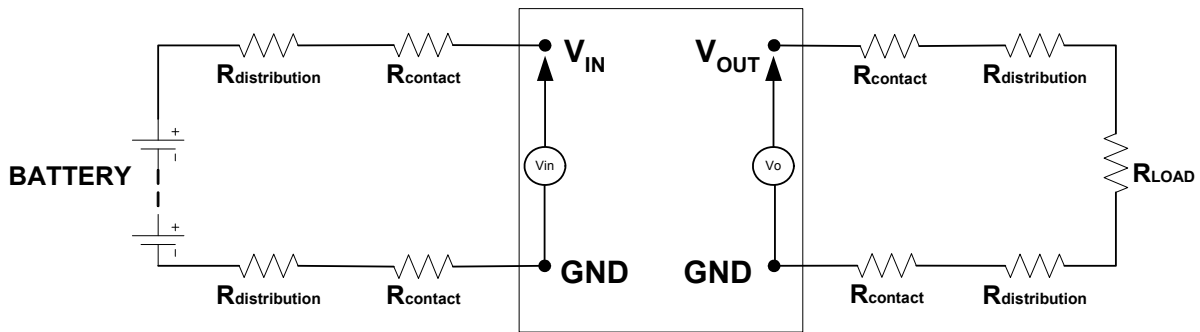

Fig 2 Test setup for efficiency

Note:

All voltage measurements must be taken at the module’s terminals, as shown above. If sockets are needed, Kelvin connections are required at the module terminals to avoid measurement errors due to socket contact resistance.

Technical Notes

EasyTrack™ Function

The EasyTrack™ function is available with the all “Point-of-Load Alliance”(PoLA) products. EasyTrack™ was designed to simplify the amount of circuitry required to make the output voltage from each module power up and power down in sequence. The sequencing of two or more supply voltages during power up is a common requirement for complex mixed-signal applications, which use dual-voltage VLSI ICs such as DSPs, micro-processors, and ASICs.

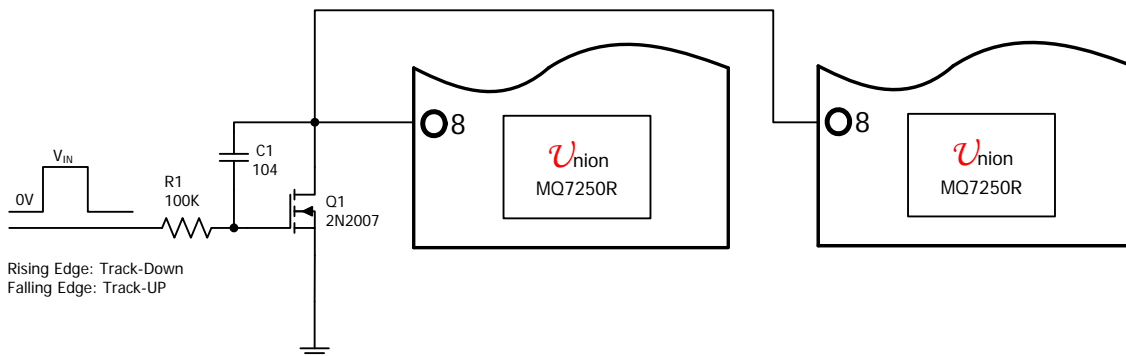

Fig 3 Simultaneous Power Up and Power Down Using EasyTrack™

How EasyTrack™ Works

EasyTrack™ works by forcing the module's output voltage to follow a voltage presented at the EasyTrack™ control pin. This control range is limited to between 0 V and the module's set-point voltage. Once the EasyTrack™ control pin voltage is raised above the set-point voltage, the module's output remains at its set-point. As an example, if the EasyTrack™ control pin of a 2.5-V regulator is at 1 V, the regulated output will be 1 V. But if the voltage at the EasyTrack™ control pin rises to 3 V, the regulated output will not go higher than 2.5 V. When under EasyTrack™ control, the regulated output from the module follows the voltage at its EasyTrack™ control pin on a volt-for-volt basis. By connecting the EasyTrack™ control pin of a number of these modules together, the output voltages will follow a common signal during power-up and power-down. The control signal can be an externally generated master ramp waveform, or the output voltage from another power supply circuit. For convenience the EasyTrack™ control incorporates an internal RC charge circuit. This operates off the module's input voltage to provide a suitable rising voltage ramp waveform.

Input Voltage Range

The MQ7250R Series can be used in a wide variety of applications, esp. most of unregulated 5V or 12V intermediate power supply bus system. Its wide input voltage ranges can tolerate worst voltage drop from cheap isolated Brick-type Bus-converter, so it reduces total system cost on power supply.

I/O Filtering

All the specifications of the MQ7250R Series are tested with specified output capacitors. However, certain input capacitors are necessary to improve the power modules' operating conditions and to reduce the ac impedance. For example, under some conditions, the power modules can't normally start up when fully loaded due to the high ac-impedance input source. External input capacitors serve primarily as energy-storage devices. They should be added close to the input pins of the MQ7250R and selected for bulk capacitance (at appropriate frequencies), low ESR, and high rms-ripple-current ratings. All external capacitors should have appropriate voltage ratings. To reduce the amount of ripple current fed back to the input supply (input reflected-ripple current), an external L-C filter can be added with the inductance as close to the power module as possible.

MQ7250R's output ripple and transient response can be improved with the increasing output capacitance. When using output capacitors, take care that the total output capacitance does not exceed MQ7250R's Maximum Capacitive Load to avoid issuing the module's over-current protection mechanism in the start-up procedure.

When an external L-C filter is added to reduce ripple on load, for best results, the filter components should be mounted close to the load circuit rather than the power module.

When testing the relationship between external capacitors and output voltage noise, the oscilloscope's probe should be applied to the module's end directly with scope probe ground less than 10mm in length.

Input Fusing

The MQ7250R Series is not internally fused. Certain applications and/or safety agencies may require the installation of fuses at the inputs of power conversion components. The selection of the fuses should conform to the following:

1. The fuse value should be selected to be greater than the maximum input current of the modules, which occurs at the minimum input voltage.
2. Use fast-blow fuses.
3. Both input traces must be capable of carrying a current of 1.5 times the value of the fuse without opening.

Safety Considerations

MQ7250R's are non-isolated DC/DC converters. In general, all DC-DC's must be installed in compliance with relevant safety-agency specifications (usually UL/IEC/EN60950). In particular, for a non-isolated converter's output voltage to meet SELV (safety extra low voltage) requirements, its input must be SELV compliant. If the output needs to be ELV (extra low voltage), the input must be ELV.

Remote Sense

MQ7250R Power Modules offer a positive output sense function on pin SENSE. The sense function enables point-of-use regulation for overcoming moderate IR drops in conductors and/or cabling. The sense line carries very little current and consequently requires a minimal cross-sectional-area conductor. As such, it is not a low-impedance point and must be treated with care in layout and cabling. Sense lines should be run adjacent to signals (preferably ground). If the remote sense is not needed the sense pin should be left open or connected to V_{OUT} directly.

Use of trim and sense functions can cause the output voltage to increase, thereby increasing output power beyond the MQ7250R's specified rating. Therefore:

$$V_{OUT} \text{ (at pins)} \times I_{OUT} \leq P \text{ (rated output power)}$$

Output ON/OFF Inhibit

Fig5, Output ON/OFF Inhibit Implementation with Open Collector/Drain transistor for positive logic control

The MQ7250R power modules feature an On/Off pin (Pin11: On/Off) for remote On/Off operation with positive logic. If not using the remote On/Off pin, leave the pin open (module will be ON). The On/Off pin signal ($V_{on/Off}$) is referenced to ground. To switch module on and off using remote On/Off, refer to Figure 5.

Output Over voltage Protection

MQ7250R Series products do not incorporate output over voltage protection. If the operating circuit requires protection against abnormal output voltage, voltage-limiting circuitry must be provided external to the power module.

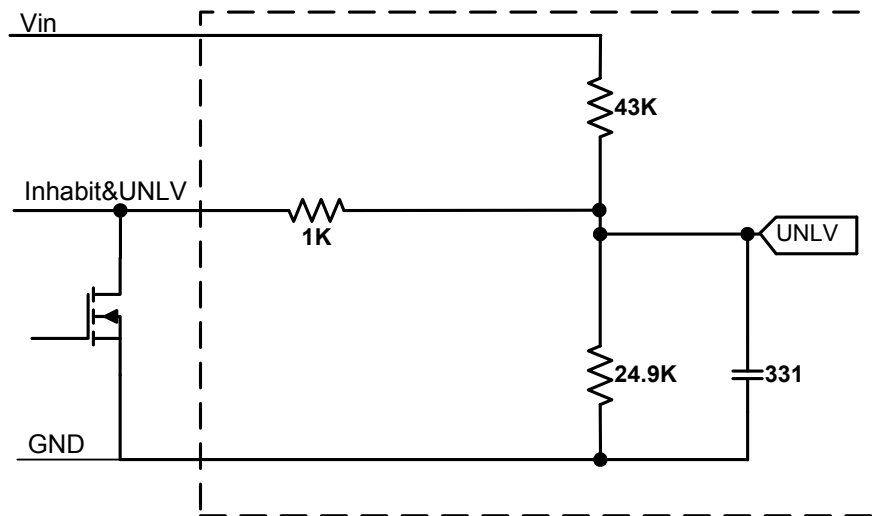
Output Overcurrent Protection (OCP)

MQ7250R incorporates over current and short circuit protection. If the load current exceeds the overcurrent protection setpoint, the MQ7250R's internal over current-protection circuitry immediately turns off the module, which then goes into Hiccup mode. The unit operates normally once the output current is brought back into its specified range. The typical average output current during hiccup is less than 0.8A.

Caution: Be careful never to operate MQ7250R in a "heavy overload" condition that is between the rated output current and the overcurrent protection setpoint. This can cause permanent damage to the components.

Over temperature Protection (OTP)

To ensure MQ7250R's reliability and avoid damaging its internal components, MQ7250R incorporates over-temperature protection circuit. When the temperature of the PCB is above 125°C, the over temperature protection circuit will be enabled and the module will stop working. When the temperature of the temperature-testing component is below about 110°C, the over temperature protection circuit will release and the module will automatically recover from shutdown. To avoid permanently damaging components, the surface temperature of MQ7250R's power components, esp. of the MOSFET (T_{REF} in Fig 6) should be ensured below 125°C.

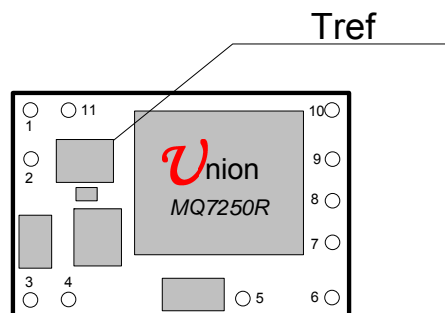

Fig 6, Temperature Reference Point

Note: The over temperature protection may be issued when MQ7250R operates in a “heavy overload” condition for a long time. Thus, the airflow should be improved.

Output Voltage Trimming

MQ7250R's output voltage can be trimmed in certain ranges. See Performance Specifications for allowable trim ranges in detail. Also customized products are offered.

Trim with external resistor (Fig 7), the equation as below:

$$R_{TRIM} = \frac{10 \times 0.69}{V_o - 0.69} - 1.43$$

Resistor values are in k Ω ; V_o is desired output voltage.

For examples, to trim output to 1.5V, then

$$R_{TRIM} = \frac{10 \times 0.69}{1.5 - 0.69} - 1.43 = 7.08$$

So, $R_{TRIM} = 6.98k\Omega$

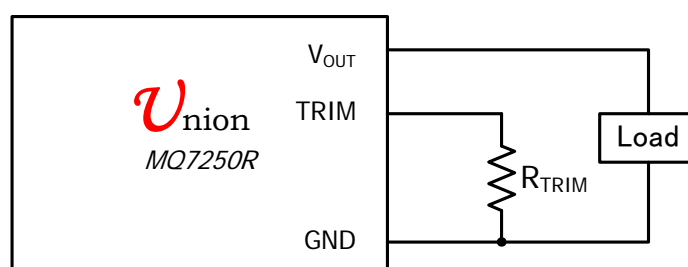

Fig7. Circuit configuration for programming output voltage using external resistor

For most common voltages, the required Trim resistors as Table 2.

Table 2, the required trim resistors R_{TRIM} for most common voltages

R_{TRIM}	V_{OUT}
OPEN	0.69V
20.5K	1.0V
12.1K	1.2V
6.98K	1.5V
4.7K	1.8V
2.37K	2.5V
1.2K	3.3V
0.169K	5.0V

Under voltage lockout (UVLO)

The MQ7250R power modules incorporate an input under voltage lockout (UVLO). The UVLO feature prevents the operation of the module until there is sufficient input voltage to produce a valid output voltage. This enables the module to provide a clean, monotonic powerup for the load circuit, and also limits the magnitude of current drawn from the regulator's input source during the power-up sequence.

The UVLO characteristic is defined by the ON threshold (V_{THD}) voltage. Below the ON threshold, the ON/OFF control is overridden, and the module does not produce an output. The hysteresis voltage, which is the difference between the ON and OFF threshold voltages, is set at 500 mV. The hysteresis prevents start-up oscillations, which can occur if the input voltage droops slightly when the module begins drawing current from the input source.

The UVLO feature of the MQ7250R module allows for limited adjustment of the ON threshold voltage. The adjustment is made via the ON/OFF control pin (pin 11) using a single resistor (see Figure 8). When pin 11 is left open circuit, the ON threshold voltage is internally set to its default value, which is 4.3 V. The ON threshold might need to be raised if the module is powered from a tightly regulated 12-V bus. Adjusting the threshold prevents the module from operating if the input bus fails to completely rise to its specified regulation voltage.

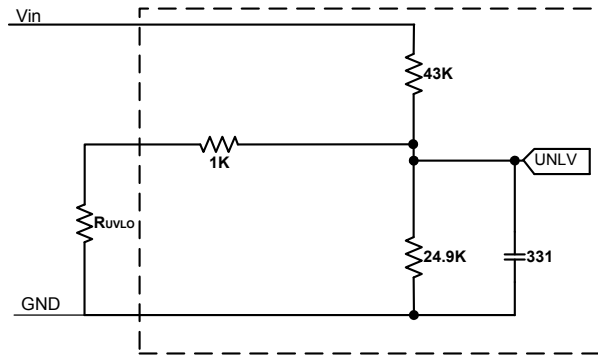

Figure 8 UVLO Implementation

The following equation determines the value of R_{UVLO} required adjusting V_{THD} to a new value. The default value is 4.3 V, and it may be adjusted, but only to a higher value.

$$R_{UVLO} = \frac{70.74 - V_{THD}}{V_{THD} - 4.26} (k\Omega)$$

The table below shows a chart of standard resistor values for R_{UVLO} for different options of the on-threshold (V_{THD}) voltage.

$V_{THD}(V)$	5.0	5.5	6.0	6.5	7.0	7.5	8.0	8.5	9.0	9.5	10.0	10.5	11.0
$R_{UVLO}(K\Omega)$	88.7	52.3	37.4	28.7	23.2	19.6	16.9	14.7	13.0	11.8	10.5	9.76	8.87

Typical Characteristics—output adjusted to 0.69V

General conditions:

Input filter 22 μ F Ceramic + 100 μ F TAN (100m Ω ESR), Output filter 22 μ F Ceramic*2 + 100 μ F TAN (100m Ω ESR)*2

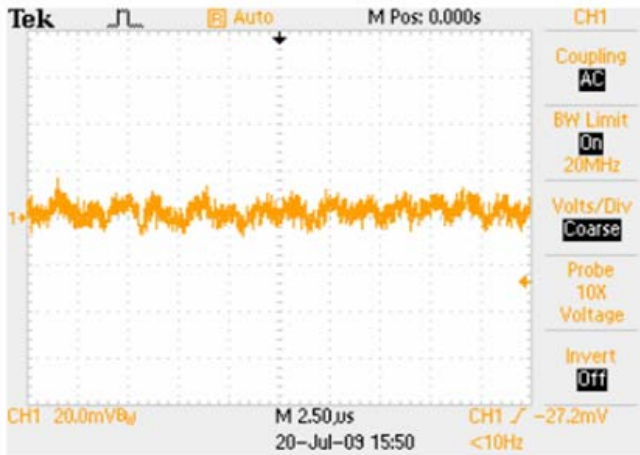

Noise $V_{IN}=5V$, $I_O=10A$, 5~20MHz Bandwidth

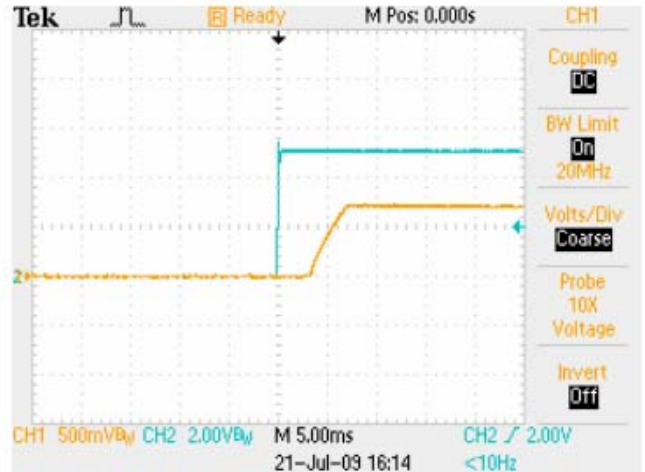

Start-up $V_{IN}=5V$, $I_O=10A$
Yellow: Output Voltage Blue: Input Voltage

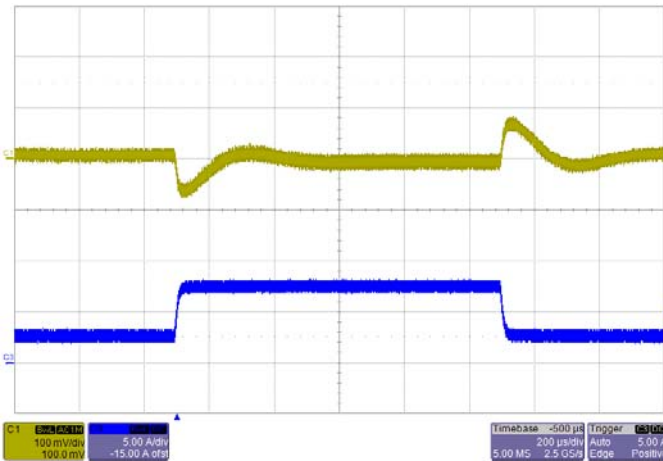

Transient Response $V_{IN}=5V$, Step from 2.5A~7.5A~2.5A,
 $C_O=220\mu F$
Blue: Load Current Yellow: Output Ripple

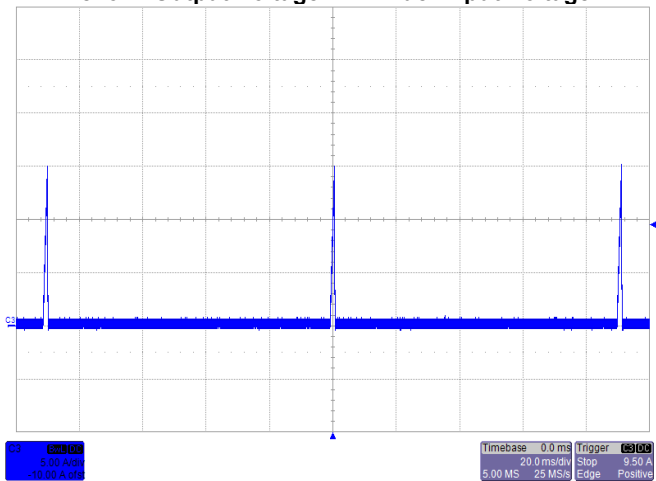

Short Circuit Protection, $V_{IN}=5V$

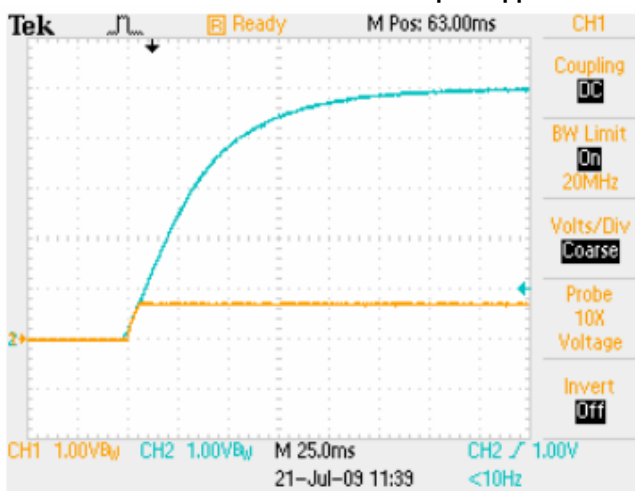

Power Up with EasyTrack™ Control $V_{Track}=5.0V$, $I_O=10A$
Blue: EasyTrack™ Control Voltage Yellow: Output Voltage



Power Down with EasyTrack™ Control $V_{Track}=5V$, $I_O=10A$
Blue: EasyTrack™ Control Voltage Yellow: Output Voltage

MQ7250R

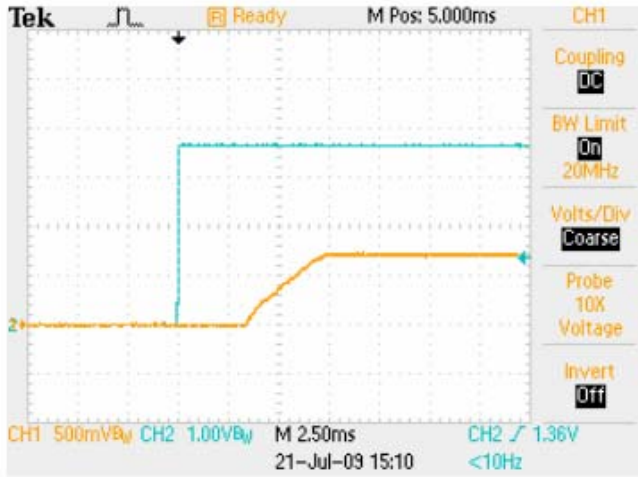

Power Up with ON/OFF Control, $V_{IN}=5V$

Blue: ON/OFF Control Voltage Yellow: Output Voltage

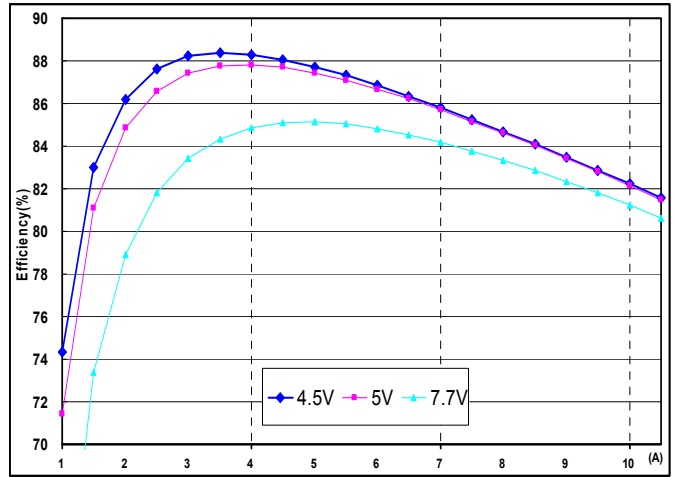

Efficiency vs. Load Current

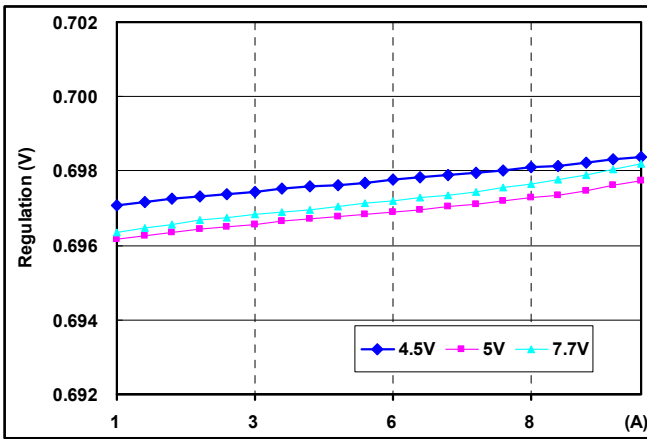

Regulation
Output voltage vs. Load Current

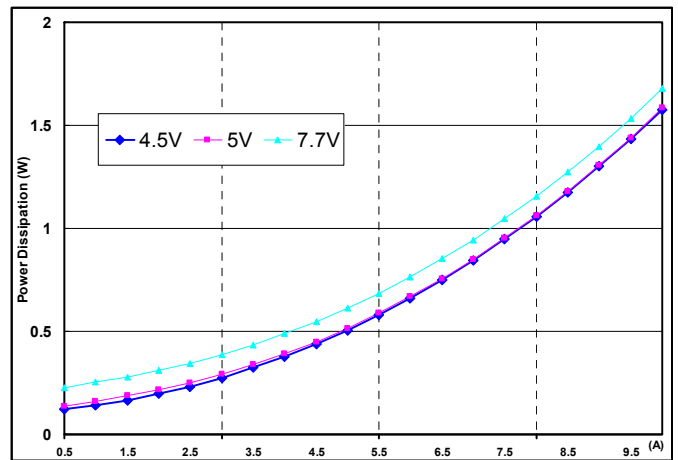

Power Dissipation vs. Load Current

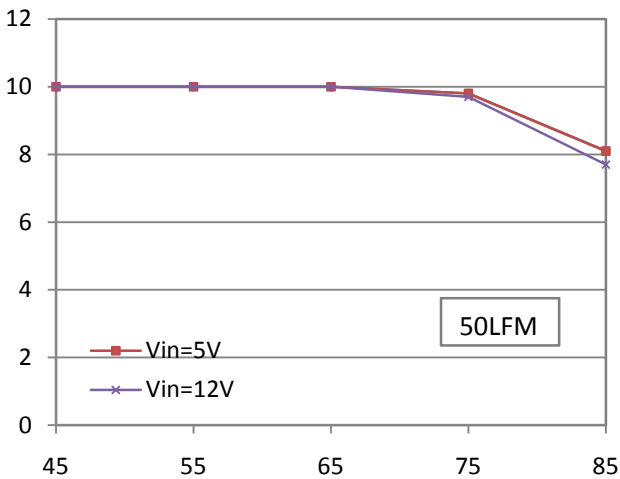

Output Current Derating

(Input filter:68uF/20V*3 TAN;
Output filter:227/10V*4 TAN+47uF/6.3V*1 (陶瓷))

Typical Characteristics—output adjusted to 1.0V

General conditions:

Input filter 22 μ F Ceramic + 100 μ F TAN (100m Ω ESR), Output filter 22 μ F Ceramic*2 + 100 μ F TAN (100m Ω ESR)*2

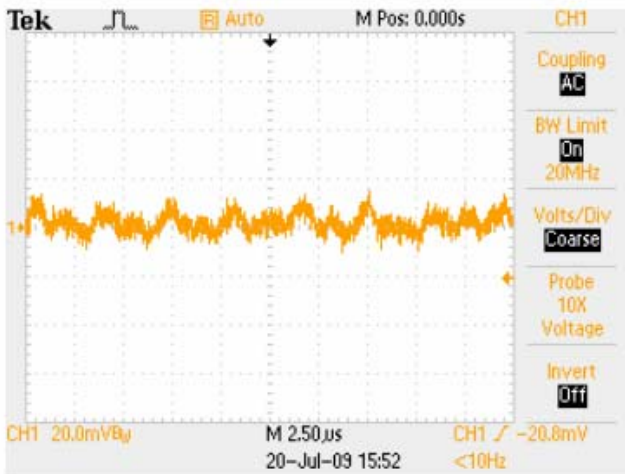

Noise $V_{IN}=5V$, $I_O=10A$, 5~20MHz Bandwidth

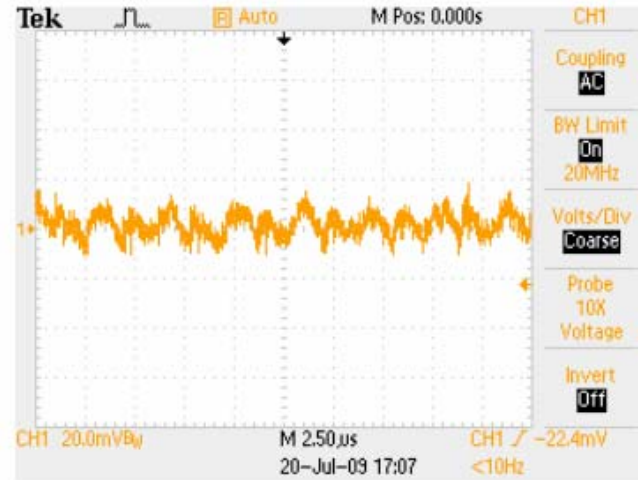

Noise $V_{IN}=11V$, $I_O=10A$, 5~20MHz Bandwidth

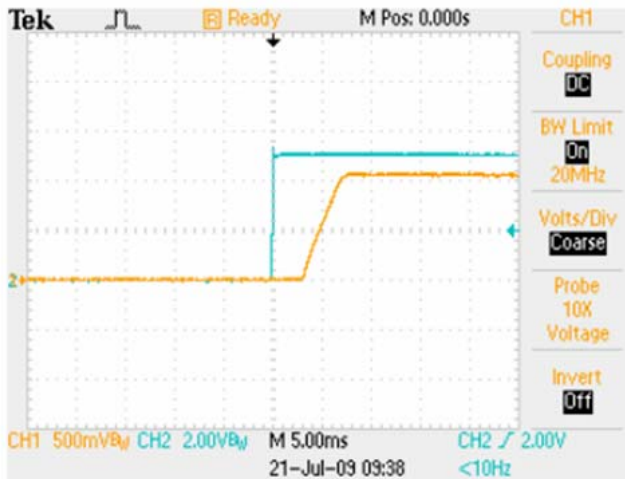

Start-up $V_{IN}=5V$, $I_O=10A$

Yellow: Output Voltage Blue: Input Voltage

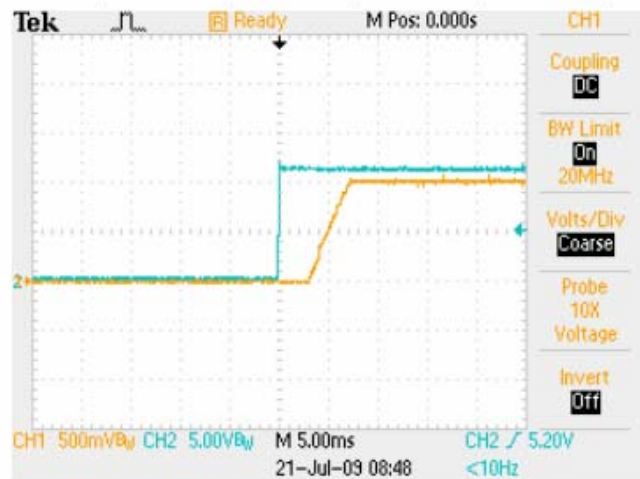

Start-up $V_{IN}=11V$, $I_O=10A$

Yellow: Output Voltage Blue: Input Voltage



Power Up with EasyTrack™ Control $V_{Track}=5.0V$, $I_O=10A$
Blue: EasyTrack™ Control Voltage Yellow: Output Voltage



Power Down with EasyTrack™ Control $V_{Track}=5V$, $I_O=10A$
Blue: EasyTrack™ Control Voltage Yellow: Output Voltage

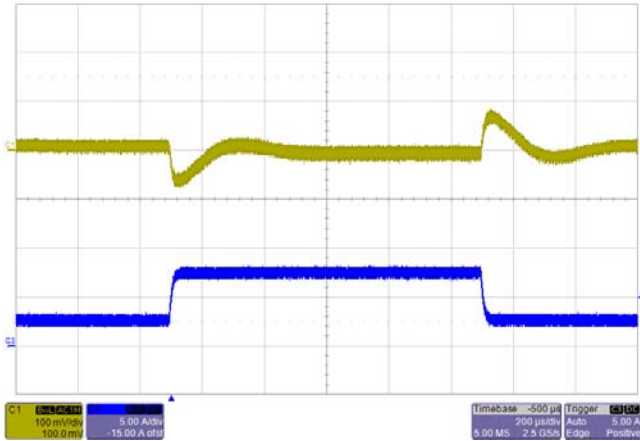

Transient Response $V_{IN}=5V$, Step from 2.5A~7.5A~2.5A, $C_o=220\mu F$

Blue: Load Current Yellow: Output Ripple

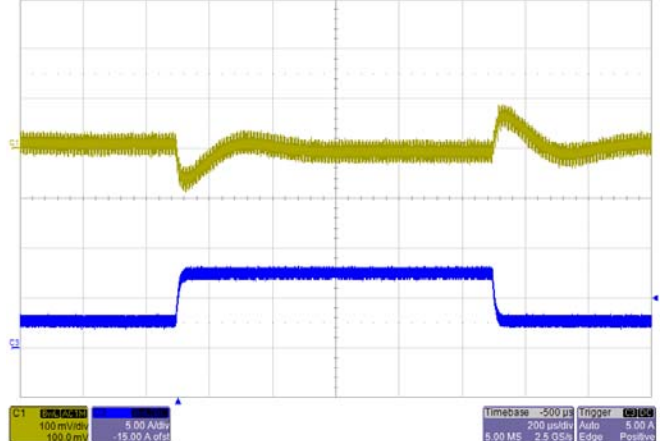

Transient Response $V_{IN}=11V$, Step from 2.5A~7.5A~2.5A, $C_o=220\mu F$

Blue: Load Current Yellow: Output Ripple

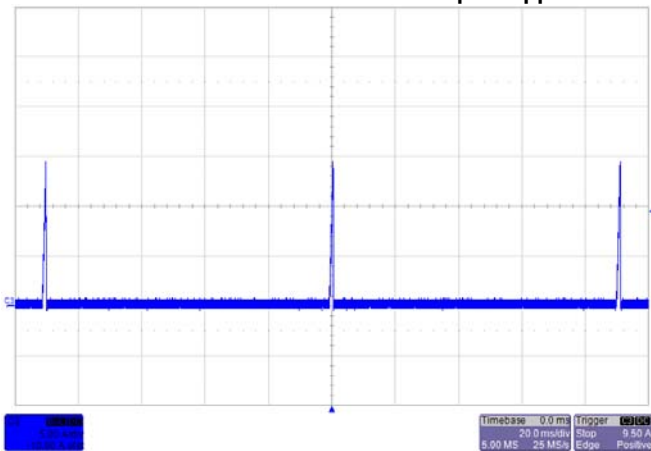

Short Circuit Protection, $V_{IN}=5V$

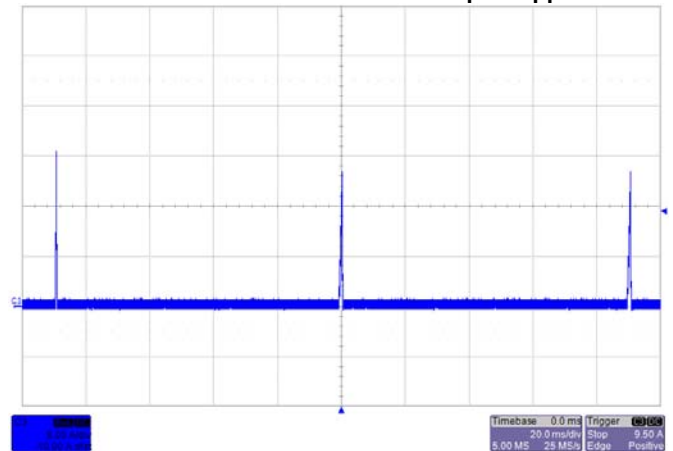

Short Circuit Protection, $V_{IN}=12V$



Power Up with ON/OFF Control, $V_{IN}=5V$

Blue: ON/OFF Control Voltage Yellow: Output Voltage



Power Up with ON/OFF Control, $V_{IN}=11V$

Blue: ON/OFF Control Voltage Yellow: Output Voltage

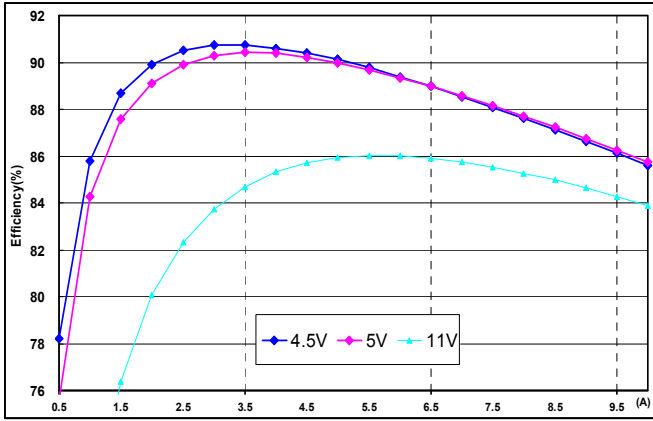

Efficiency vs. Load Current

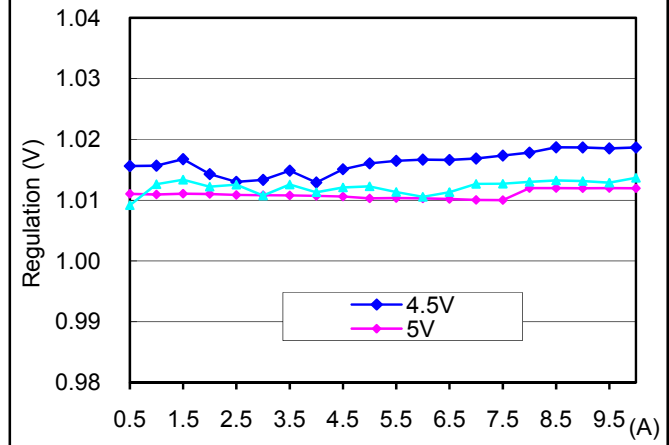

Regulation
Output voltage vs. Load Current

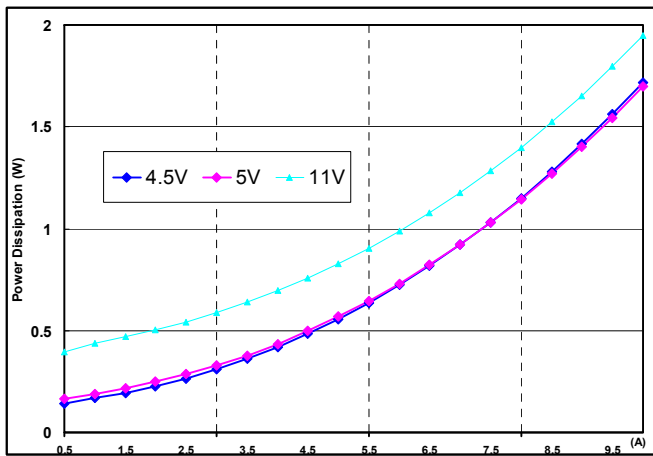

Power Dissipation vs. Load Current

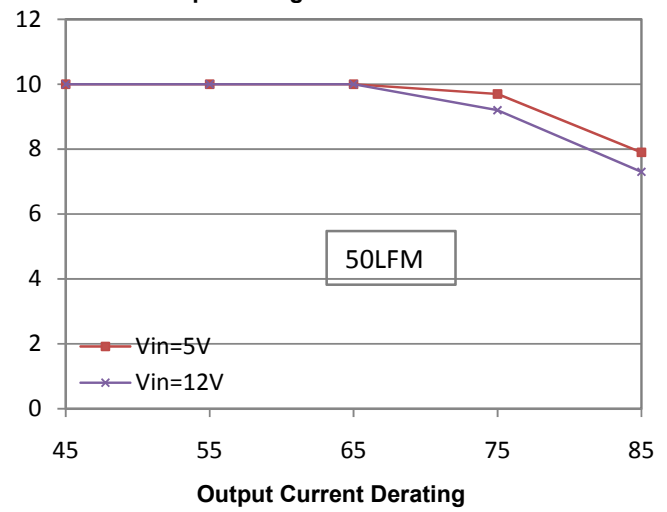

Output Current Derating
(Input filter:68uF/20V*3 TAN;
Output filter:227/10V*4 TAN+47uF/6.3V*1 (陶瓷))

Typical Characteristics—output adjusted to 1.2V

General conditions:

Input filter 22 μ F Ceramic + 100 μ F TAN (100m Ω ESR), Output filter 22 μ F Ceramic*2 + 100 μ F TAN (100m Ω ESR)*2

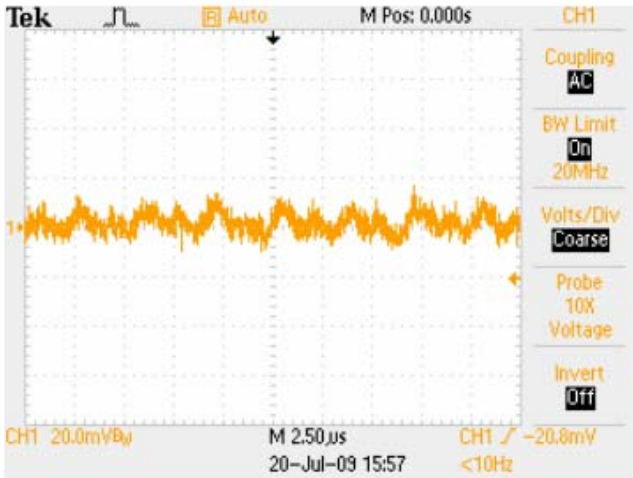

Noise $V_{IN}=5V$, $I_O=10A$, 5~20MHz Bandwidth

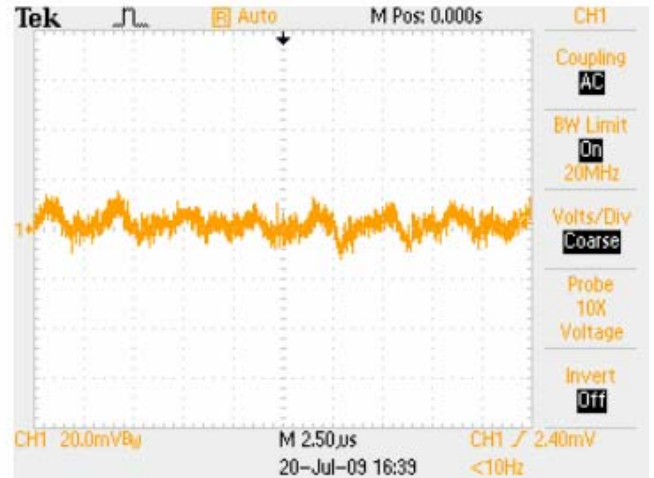

Noise $V_{IN}=12V$, $I_O=10A$, 5~20MHz Bandwidth

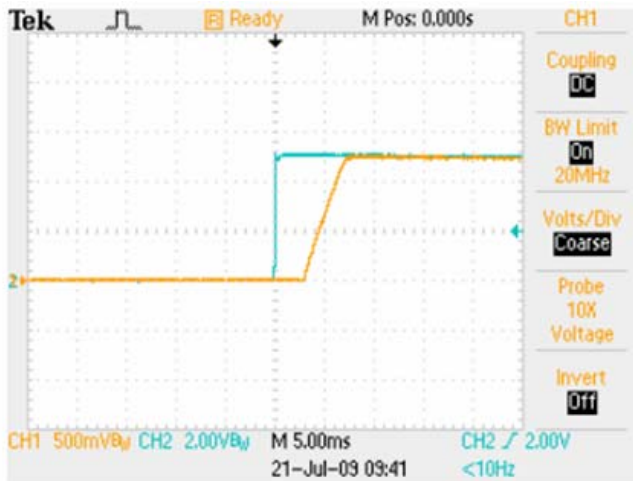

Start-up $V_{IN}=5V$, $I_O=10A$
Yellow: Output Voltage Blue: Input Voltage



Start-up $V_{IN}=12V$, $I_O=10A$
Yellow: Output Voltage Blue: Input Voltage



Power Up with *EasyTrack*™ Control $V_{Track}=5.0V$, $I_O=10A$
Blue: *EasyTrack*™ Control Voltage Yellow: Output Voltage



Power Down with *EasyTrack*™ Control $V_{Track}=5V$, $I_O=10A$
Blue: *EasyTrack*™ Control Voltage Yellow: Output Voltage

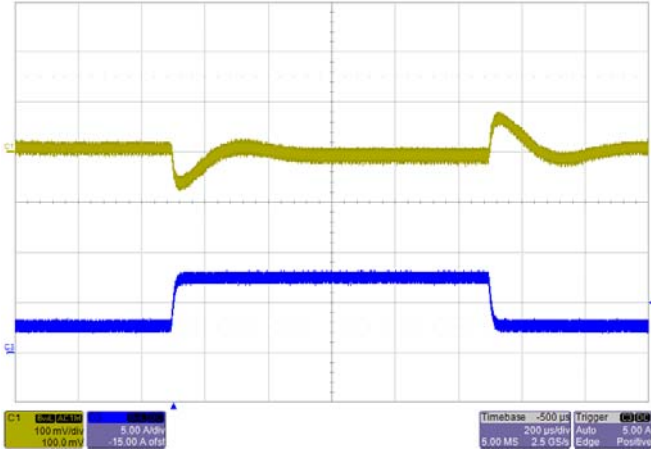

Transient Response $V_{IN}=5V$, Step from 2.5A~7.5A~2.5A,
 $C_o=220\mu F$
 Blue: Load Current Yellow: Output Ripple

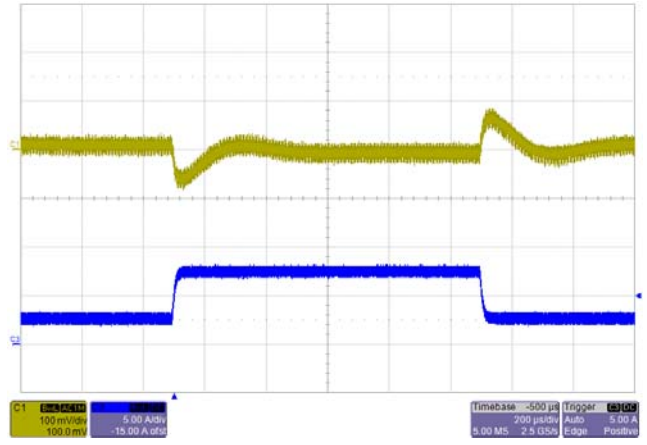

Transient Response $V_{IN}=12V$, Step from 2.5A~7.5A~2.5A,
 $C_o=220\mu F$
 Blue: Load Current Yellow: Output Ripple

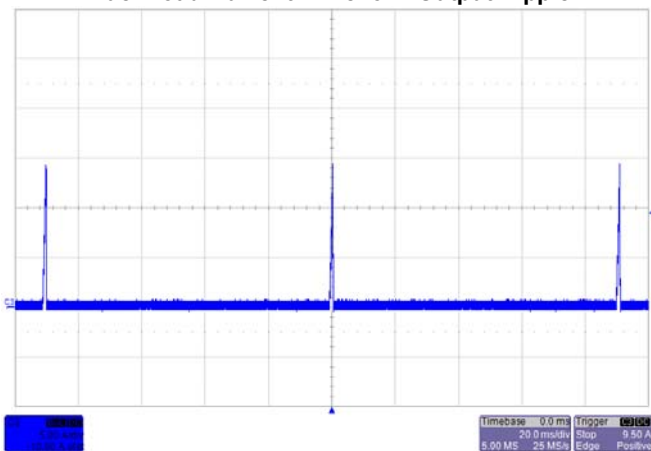

Short Circuit Protection, $V_{IN}=5V$

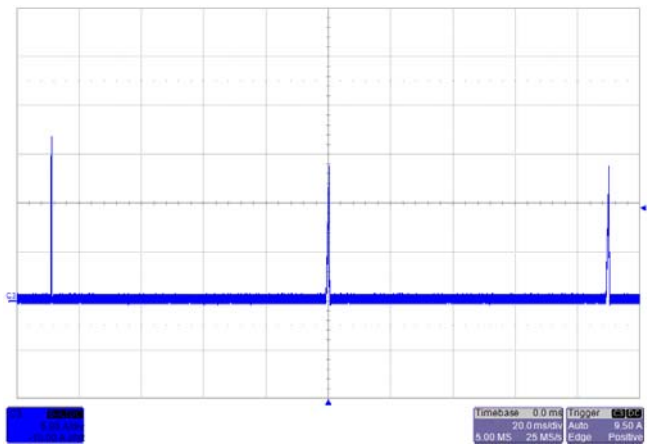

Short Circuit Protection, $V_{IN}=12V$



Power Up with ON/OFF Control, $V_{IN}=5V$
 Blue: ON/OFF Control Voltage Yellow: Output Voltage



Power Up with ON/OFF Control, $V_{IN}=12V$
 Blue: ON/OFF Control Voltage Yellow: Output Voltage

MQ7250R

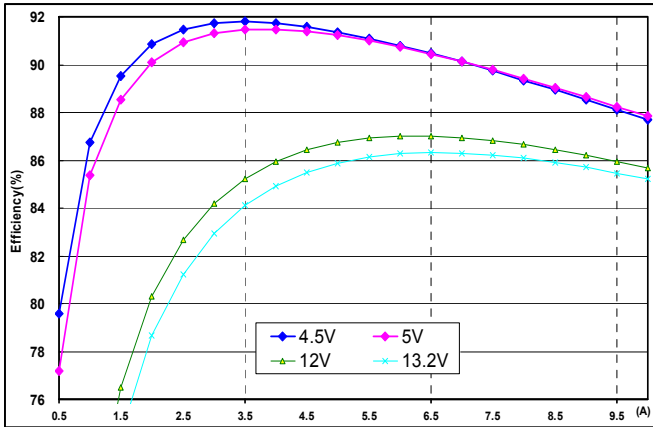

Efficiency vs. Load Current

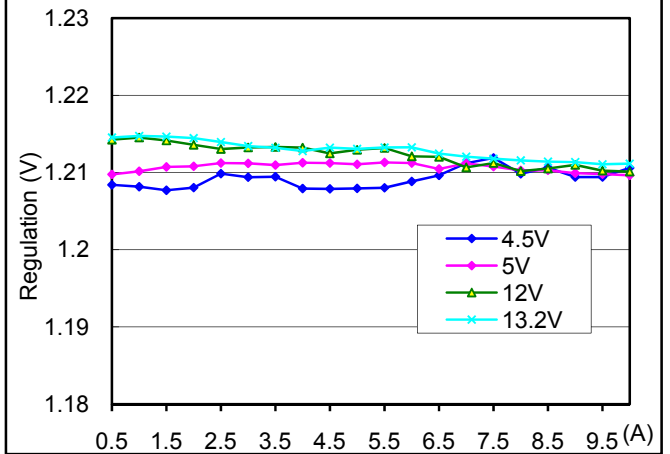

Regulation
Output voltage vs. Load Current

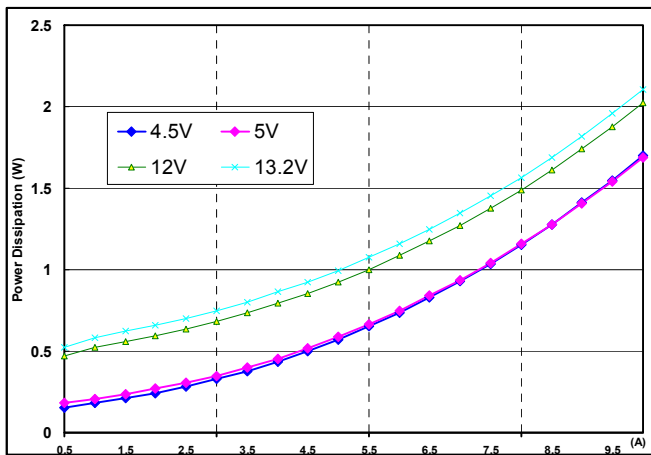

Power Dissipation vs. Load Current

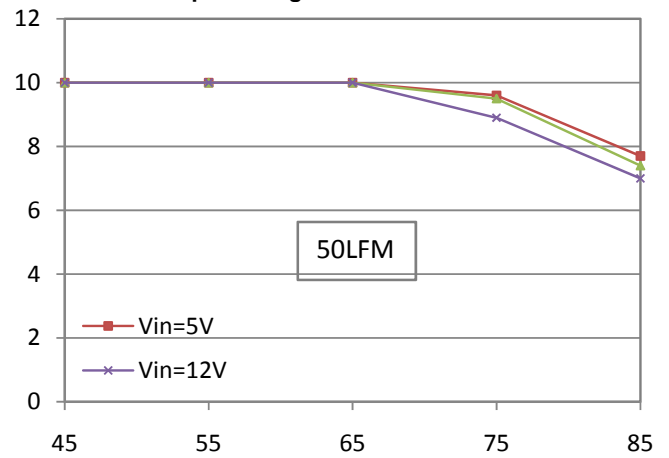

Output Current Derating

(Input filter:68uF/20V*3 TAN;
Output filter:227/10V*4 TAN+47uF/6.3V*1 (陶瓷))

Typical Characteristics—output adjusted to 1.5V

General conditions:

Input filter 22 μ F Ceramic + 100 μ F TAN (100m Ω ESR), Output filter 22 μ F Ceramic*2 + 100 μ F TAN (100m Ω ESR)*2

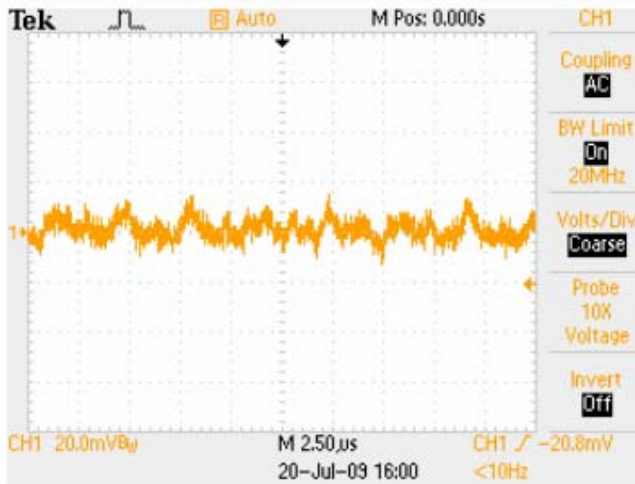

Noise $V_{IN}=5V$, $I_O=10A$, 5~20MHz Bandwidth



Noise $V_{IN}=12V$, $I_O=10A$, 5~20MHz Bandwidth



Start-up $V_{IN}=5V$, $I_O=10A$
Yellow: Output Voltage Blue: Input Voltage

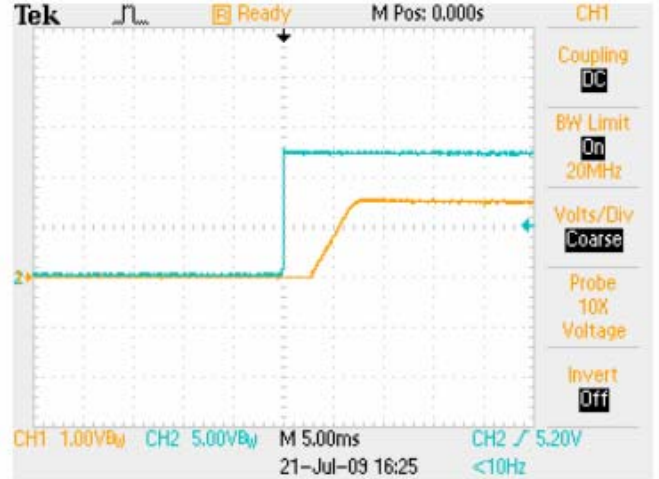

Start-up $V_{IN}=12V$, $I_O=10A$
Yellow: Output Voltage Blue: Input Voltage

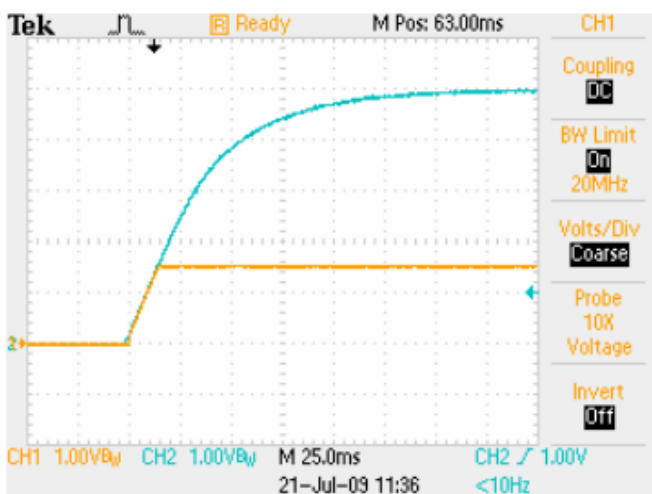

Power Up with *EasyTrack*TM Control $V_{Track}=5.0V$, $I_O=10A$
Blue: *EasyTrack*TM Control Voltage Yellow: Output Voltage

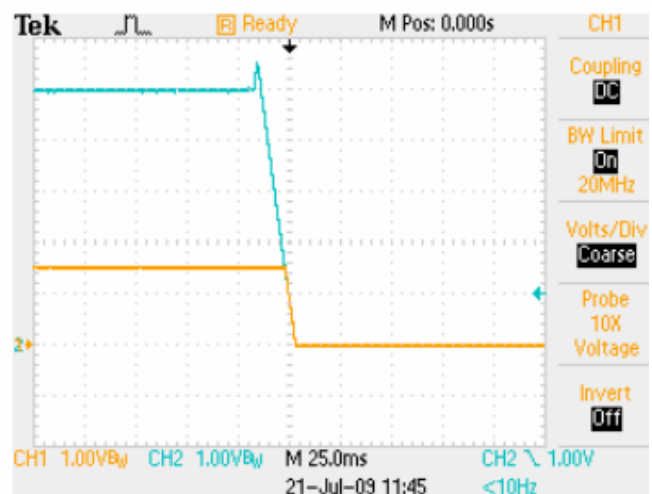

Power Down with *EasyTrack*TM Control $V_{Track}=5V$, $I_O=10A$
Blue: *EasyTrack*TM Control Voltage Yellow: Output Voltage

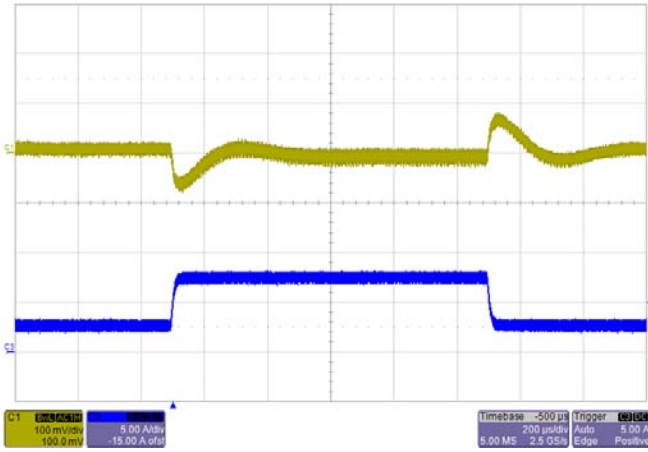

Transient Response $V_{IN}=5V$, Step from 2.5A~7.5A~2.5A,
 $C_o=220\mu F$
 Blue: Load Current Yellow: Output Ripple

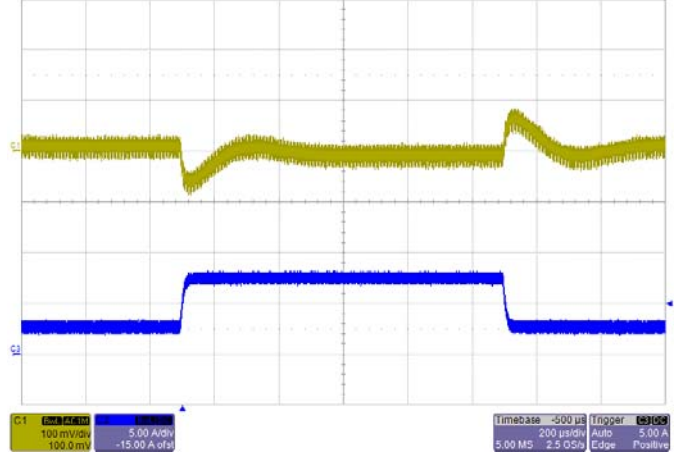

Transient Response $V_{IN}=12V$, Step from 2.5A~7.5A~2.5A,
 $C_o=220\mu F$
 Blue: Load Current Yellow: Output Ripple

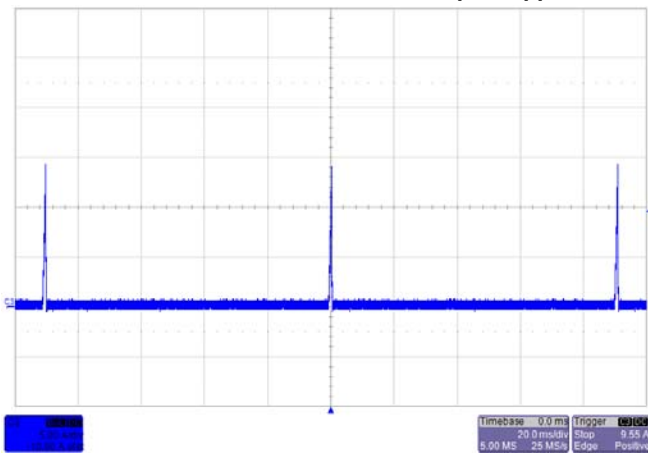

Short Circuit Protection, $V_{IN}=5V$

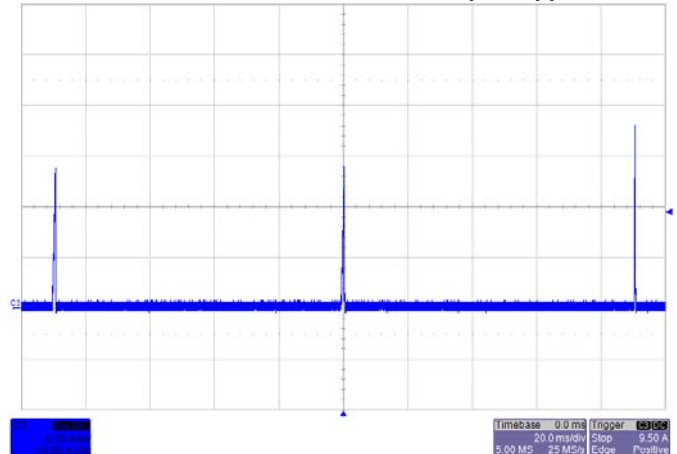

Short Circuit Protection, $V_{IN}=12V$



Power Up with ON/OFF Control, $V_{IN}=5V$
 Blue: ON/OFF Control Voltage Yellow: Output Voltage

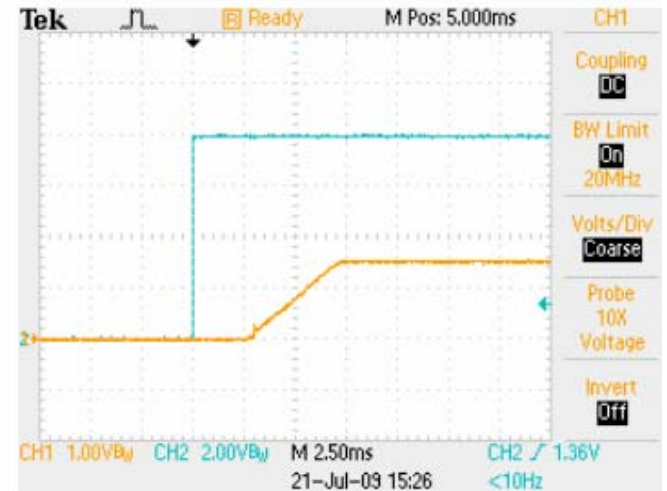

Power Up with ON/OFF Control, $V_{IN}=12V$
 Blue: ON/OFF Control Voltage Yellow: Output Voltage

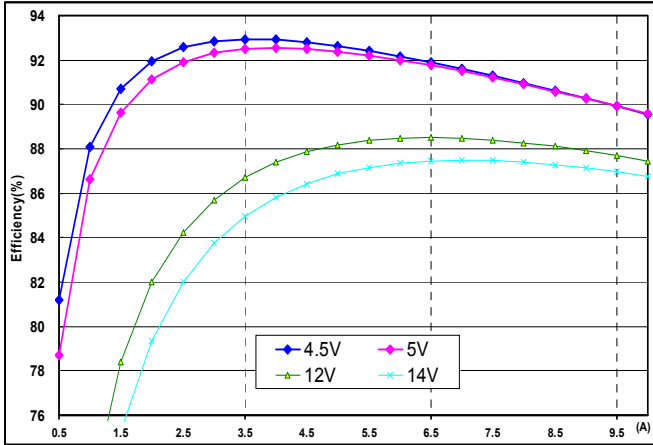

Efficiency vs. Load Current

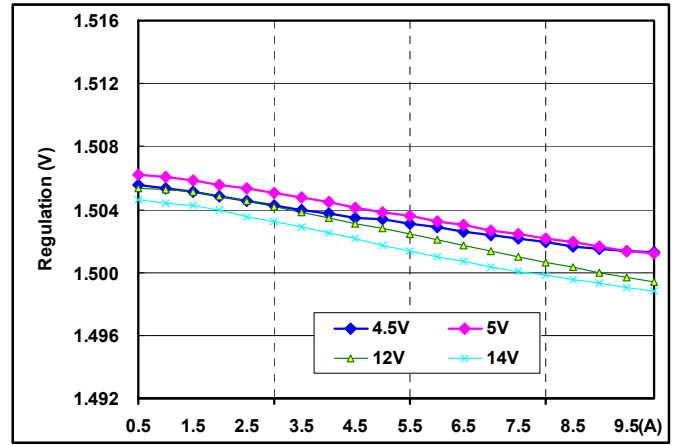

Regulation
Output voltage vs. Load Current

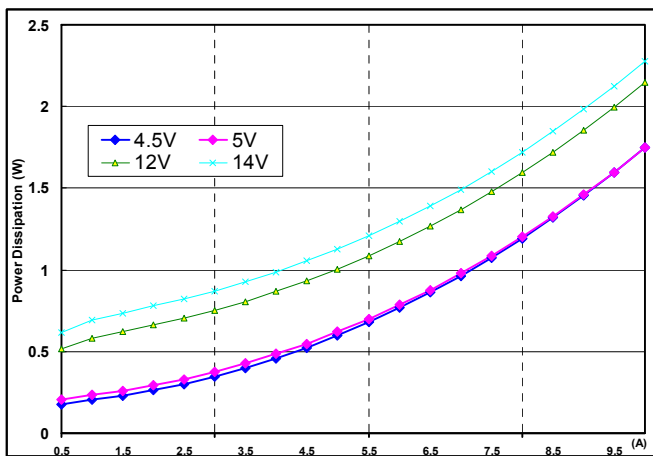

Power Dissipation vs. Load Current

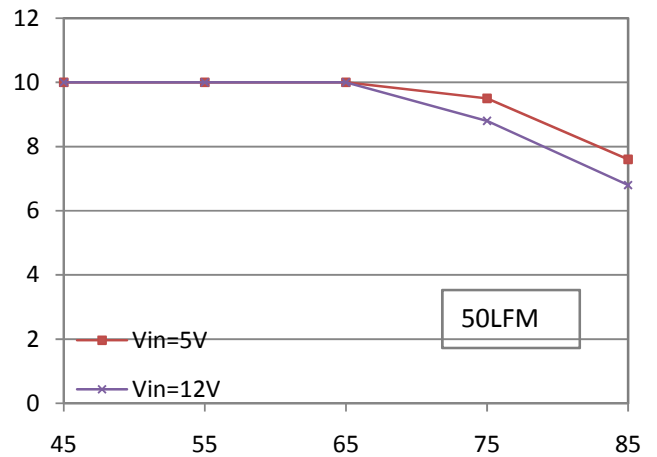

Output Current Derating

(Input filter:68uF/20V*3 TAN;
Output filter:227/10V*4 TAN+47uF/6.3V*1 (陶瓷))

Typical Characteristics—output adjusted to 1.8V

General conditions:

Input filter 22 μ F Ceramic + 100 μ F TAN (100m Ω ESR), Output filter 22 μ F Ceramic*2 + 100 μ F TAN (100m Ω ESR)*2

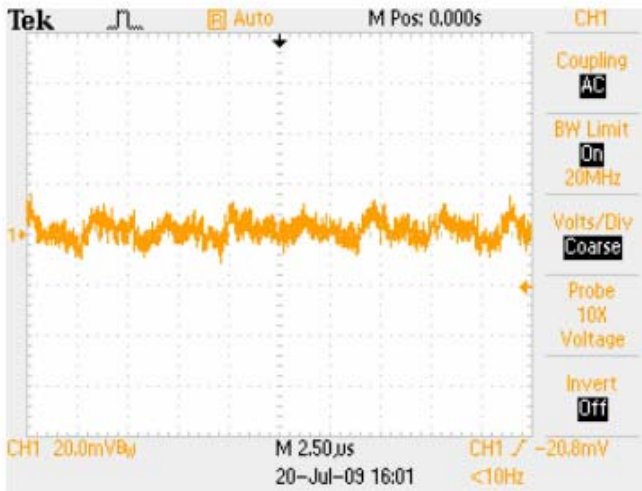

Noise $V_{IN}=5V$, $I_O=10A$, 5~20MHz Bandwidth

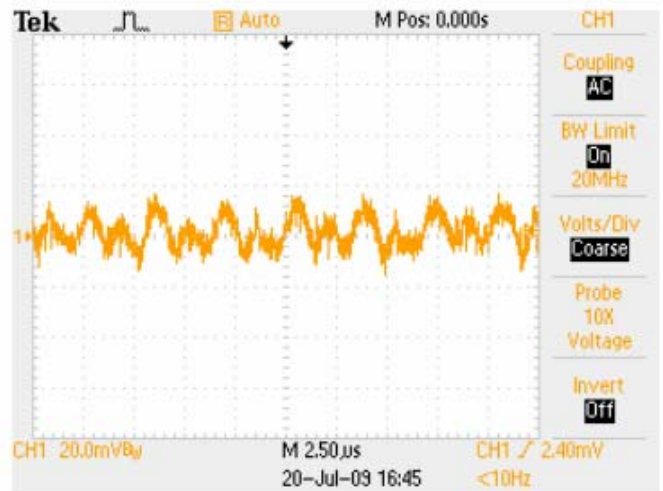

Noise $V_{IN}=12V$, $I_O=10A$, 5~20MHz Bandwidth



Start-up $V_{IN}=5V$, $I_O=10A$
Yellow: Output Voltage Blue: Input Voltage

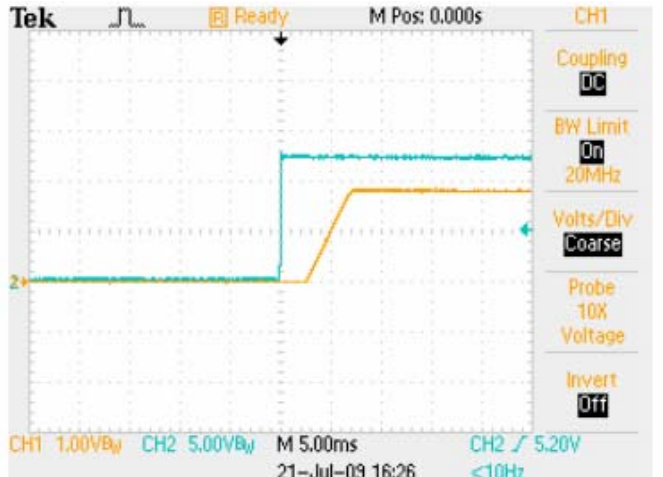

Start-up $V_{IN}=12V$, $I_O=10A$
Yellow: Output Voltage Blue: Input Voltage

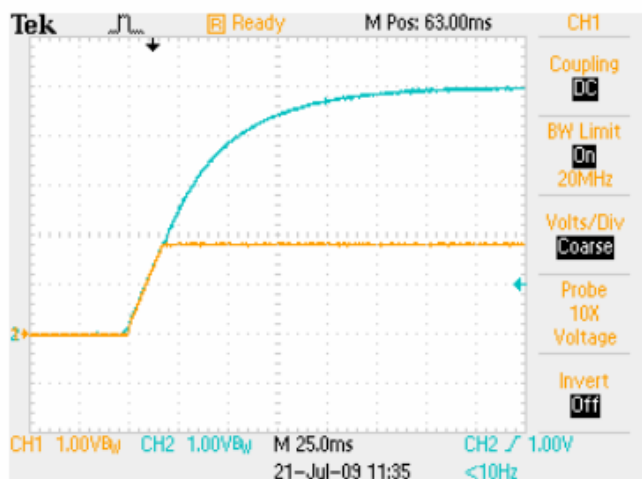

Power Up with *EasyTrack*TM Control $V_{Track}=5.0V$, $I_O=10A$
Blue: *EasyTrack*TM Control Voltage Yellow: Output Voltage

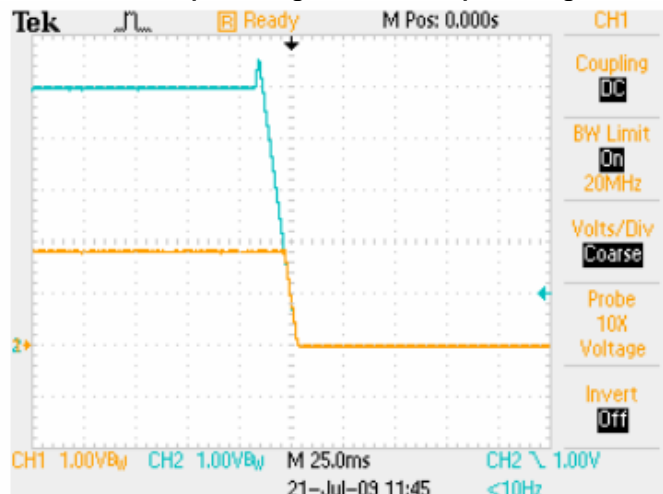

Power Down with *EasyTrack*TM Control $V_{Track}=5V$, $I_O=10A$
Blue: *EasyTrack*TM Control Voltage Yellow: Output Voltage

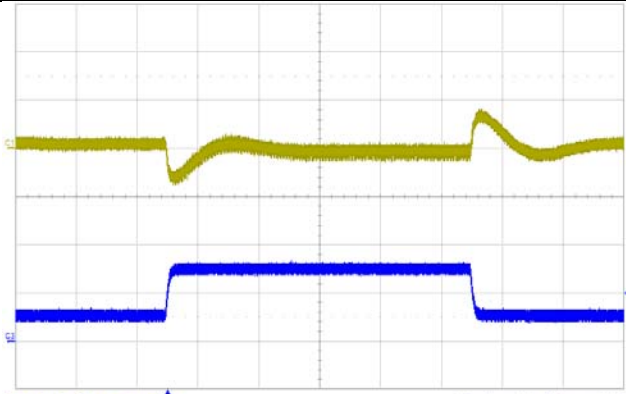

Transient Response $V_{IN}=5V$, Step from 2.5A~7.5A~2.5A, $C_o=220\mu F$
Blue: Load Current Yellow: Output Ripple

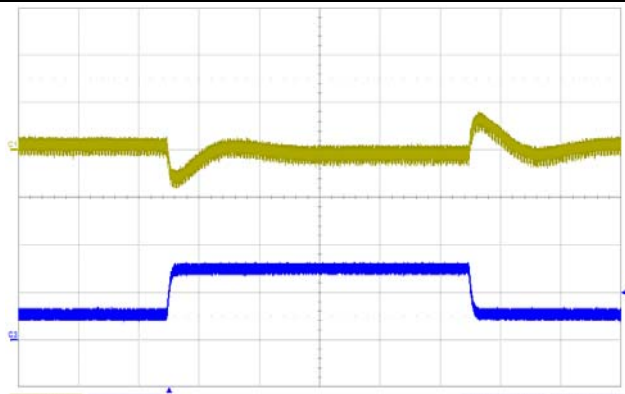

Transient Response $V_{IN}=12V$, Step from 2.5A~7.5A~2.5A, $C_o=220\mu F$
Blue: Load Current Yellow: Output Ripple

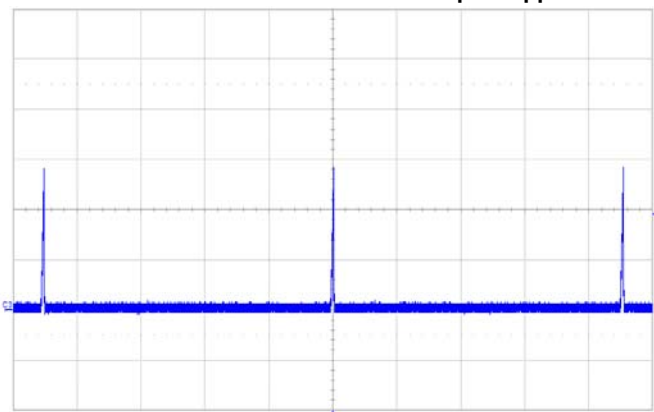

Short Circuit Protection, $V_{IN}=5V$

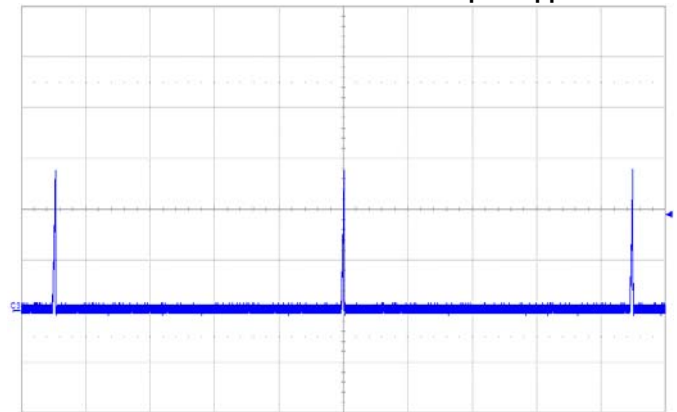

Short Circuit Protection, $V_{IN}=12V$

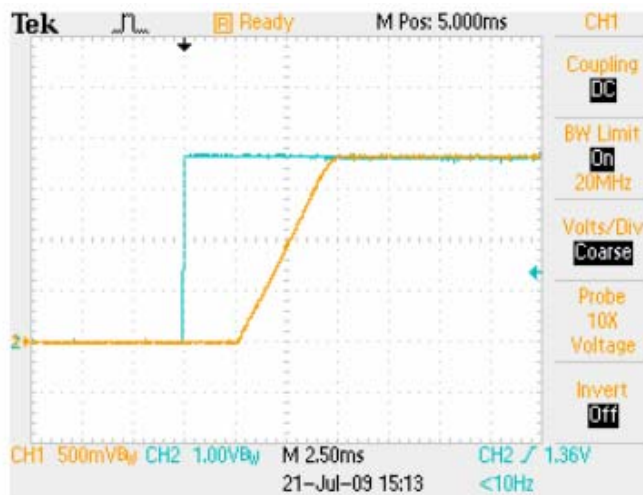

Power Up with ON/OFF Control, $V_{IN}=5V$

Blue: ON/OFF Control Voltage Yellow: Output Voltage

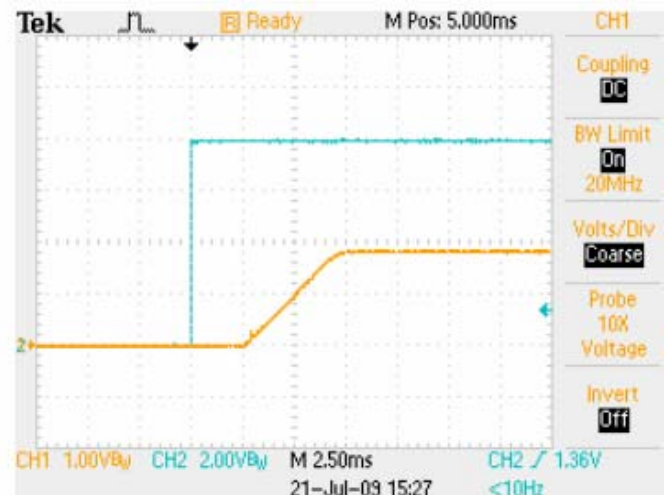

Power Up with ON/OFF Control, $V_{IN}=12V$

Blue: ON/OFF Control Voltage Yellow: Output Voltage

MQ7250R

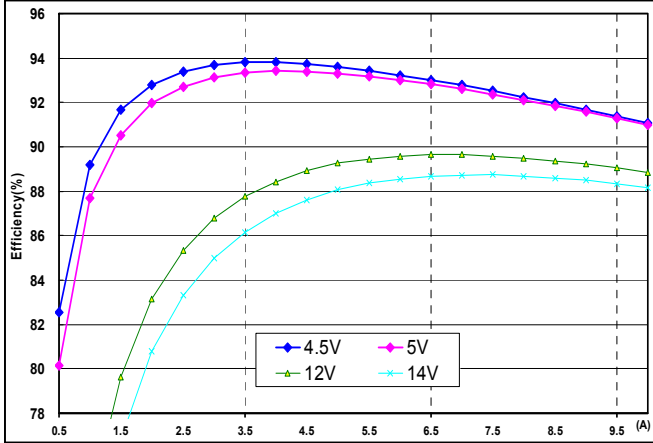

Efficiency vs. Load Current

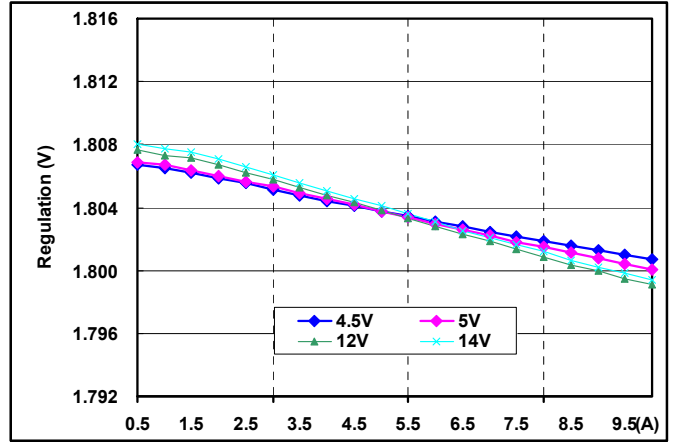

Regulation Output voltage vs. Load Current

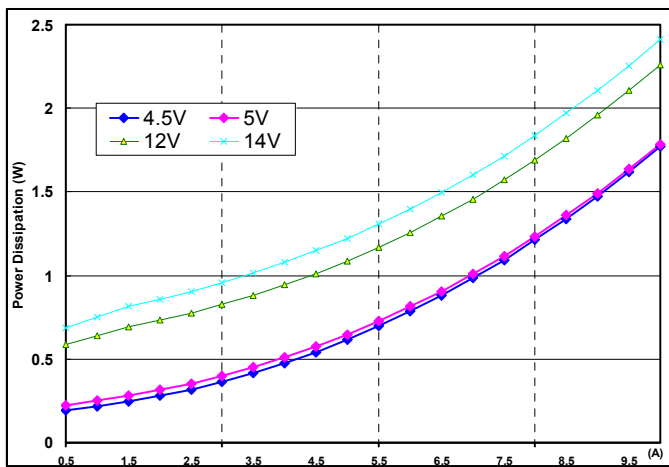

Power Dissipation vs. Load Current

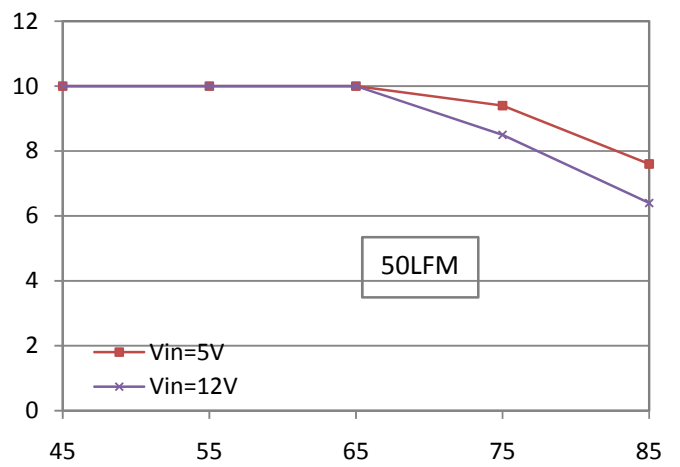

Output Current Derating

(Input filter:68uF/20V*3 TAN;
Output filter:227/10V*4 TAN+47uF/6.3V*1 (陶瓷))

Typical Characteristics—output adjusted to 2.5V

General conditions:

Input filter 22 μ F Ceramic + 100 μ F TAN (100m Ω ESR), Output filter 22 μ F Ceramic*2 + 100 μ F TAN (100m Ω ESR)*2

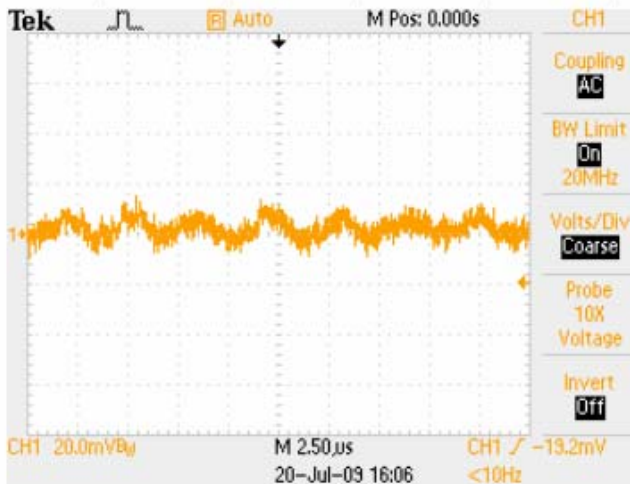

Noise $V_{IN}=5V$, $I_O=10A$, 5~20MHz Bandwidth

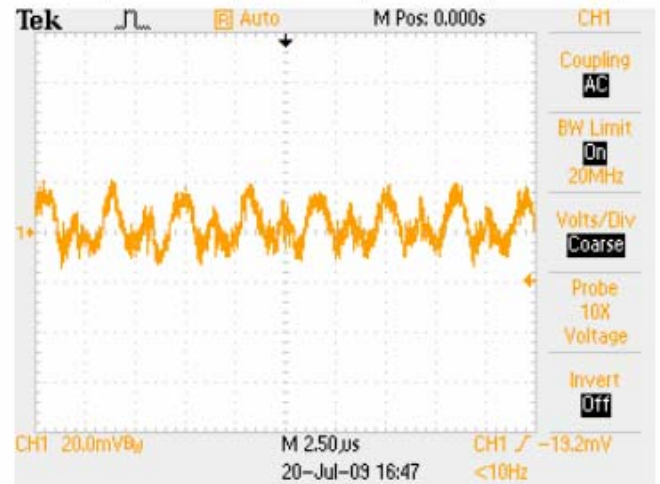

Noise $V_{IN}=12V$, $I_O=10A$, 5~20MHz Bandwidth



Start-up $V_{IN}=5V$, $I_O=10A$
Yellow: Output Voltage Blue: Input Voltage



Start-up $V_{IN}=12V$, $I_O=10A$
Yellow: Output Voltage Blue: Input Voltage

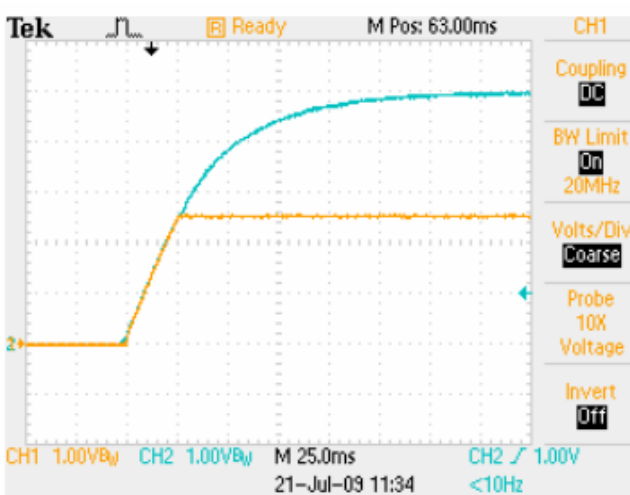

Power Up with *EasyTrack*TM Control $V_{Track}=5.0V$, $I_O=10A$
Blue: *EasyTrack*TM Control Voltage Yellow: Output Voltage

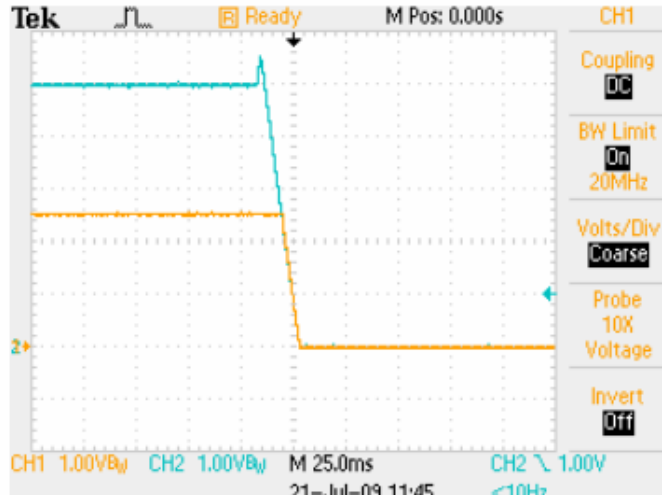

Power Down with *EasyTrack*TM Control $V_{Track}=5V$, $I_O=10A$
Blue: *EasyTrack*TM Control Voltage Yellow: Output Voltage

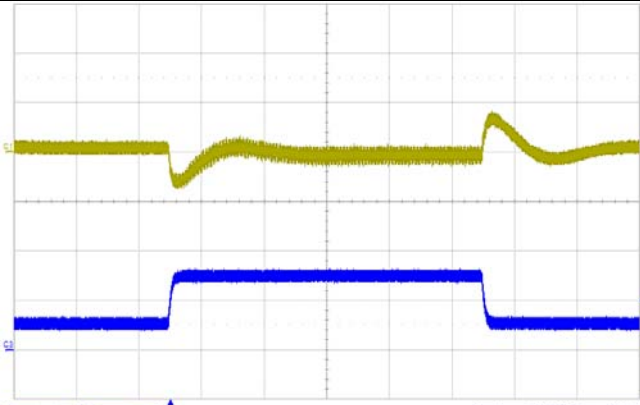

Transient Response $V_{IN}=5V$, Step from 2.5A~7.5A~2.5A,
 $C_o=220\mu F$
 Blue: Load Current Yellow: Output Ripple

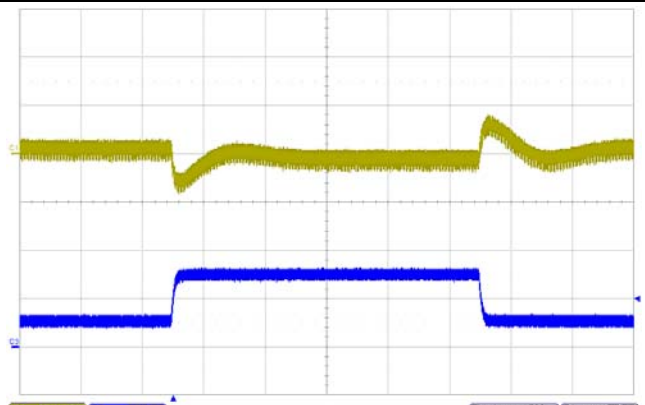

Transient Response $V_{IN}=12V$, Step from 2.5A~7.5A~2.5A,
 $C_o=220\mu F$
 Blue: Load Current Yellow: Output Ripple

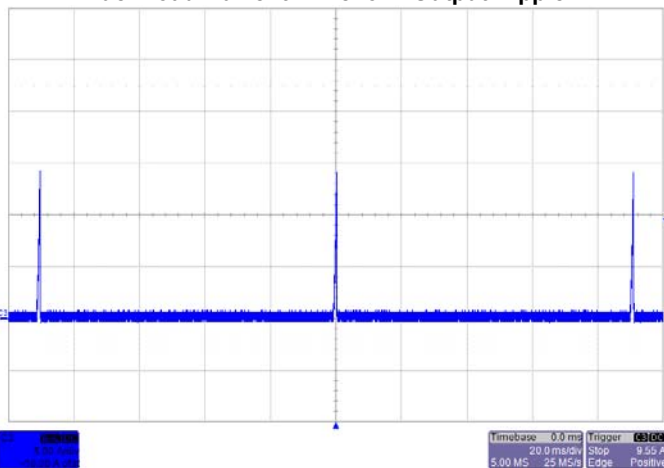

Short Circuit Protection, $V_{IN}=5V$

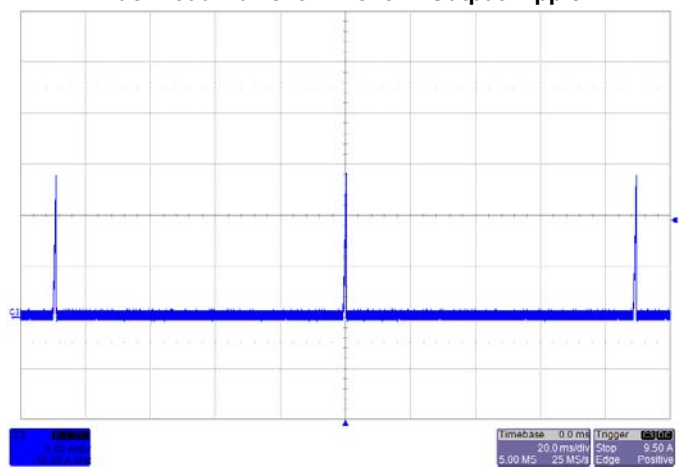

Short Circuit Protection, $V_{IN}=12V$



Power Up with ON/OFF Control, $V_{IN}=5V$
 Blue: ON/OFF Control Voltage Yellow: Output Voltage



Power Up with ON/OFF Control, $V_{IN}=12V$
 Blue: ON/OFF Control Voltage Yellow: Output Voltage

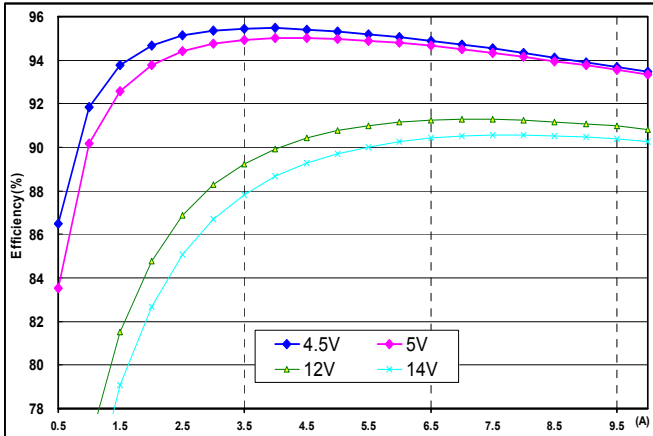

Efficiency vs. Load Current

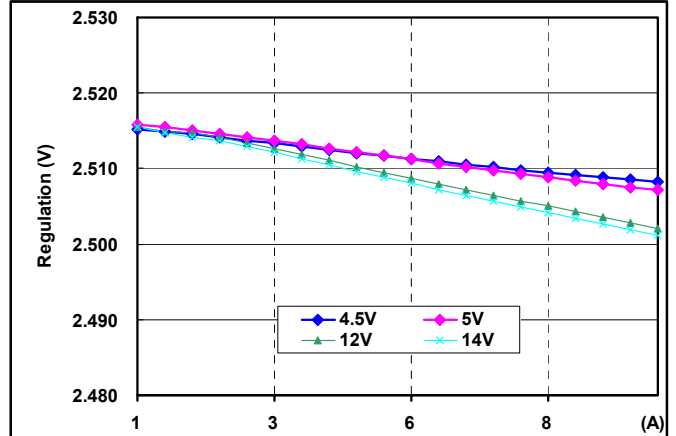

Regulation
Output voltage vs. Load Current

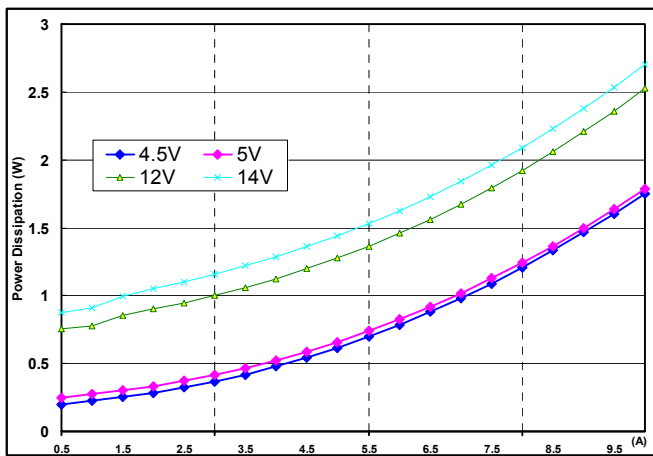

Power Dissipation vs. Load Current

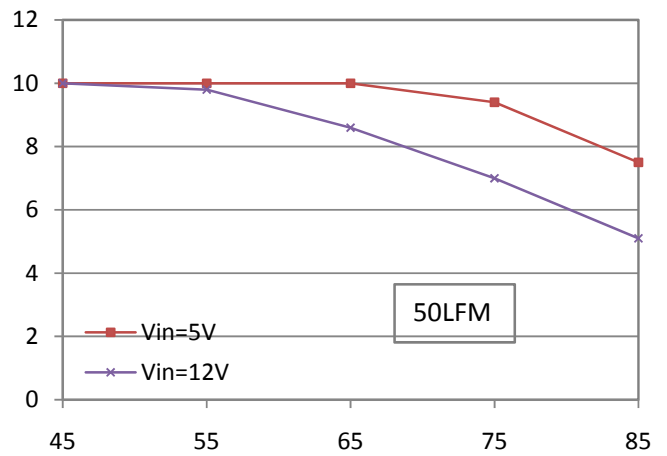

Output Current Derating

(Input filter:68uF/20V*3 TAN;
Output filter:227/10V*4 TAN+47uF/6.3V*1 (陶瓷))

Typical Characteristics—output adjusted to 3.3V

General conditions:

Input filter 22 μ F Ceramic + 100 μ F TAN (100m Ω ESR), Output filter 22 μ F Ceramic*2 + 100 μ F TAN (100m Ω ESR)*2

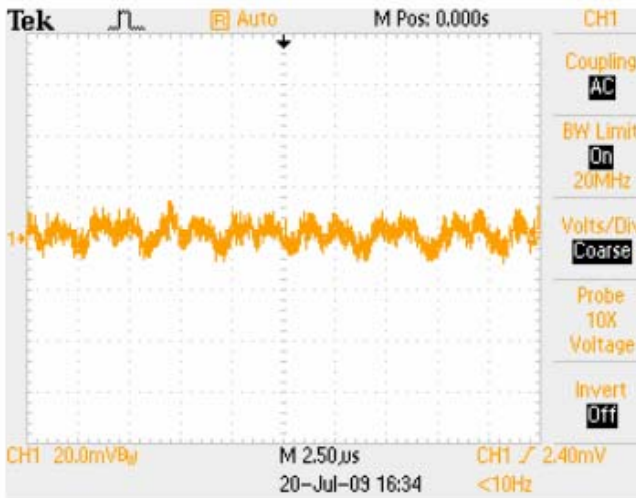

Noise $V_{IN}=5V$, $I_O=10A$, 5~20MHz Bandwidth

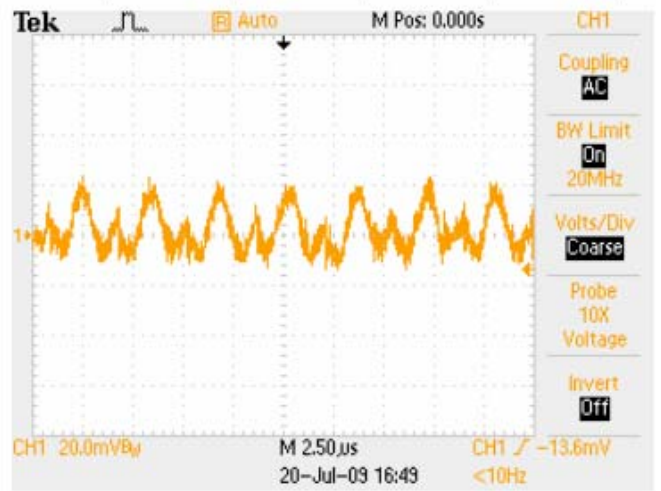

Noise $V_{IN}=12V$, $I_O=10A$, 5~20MHz Bandwidth

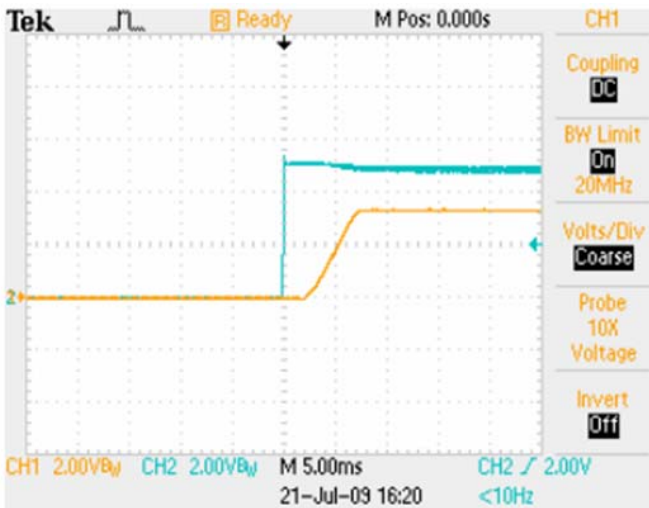

Start-up $V_{IN}=5V$, $I_O=10A$
Yellow: Output Voltage Blue: Input Voltage

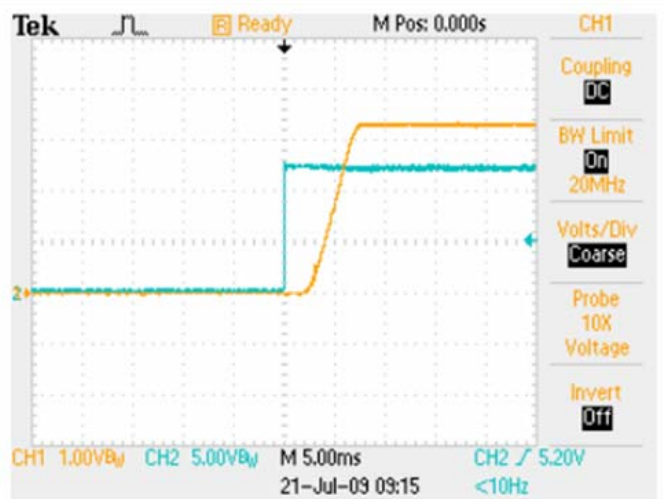

Start-up $V_{IN}=12V$, $I_O=10A$
Yellow: Output Voltage Blue: Input Voltage

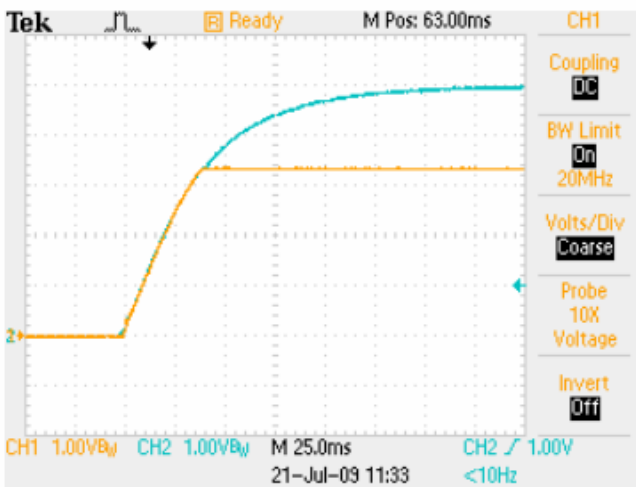

Power Up with *EasyTrack*TM Control $V_{Track}=5.0V$, $I_O=10A$
Blue: *EasyTrack*TM Control Voltage Yellow: Output Voltage

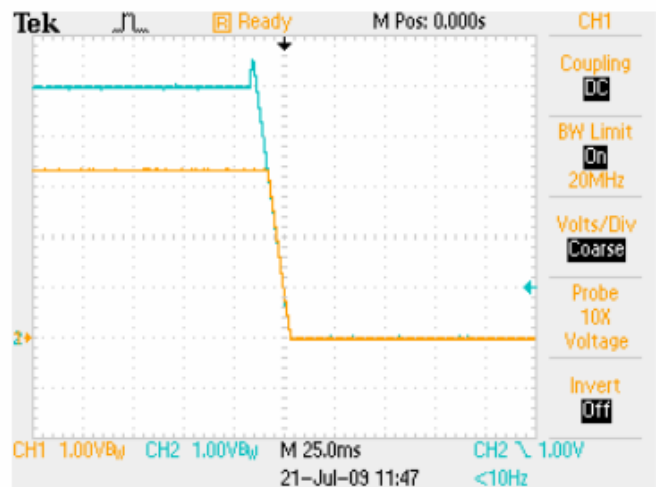

Power Down with *EasyTrack*TM Control $V_{Track}=5V$, $I_O=10A$
Blue: *EasyTrack*TM Control Voltage Yellow: Output Voltage

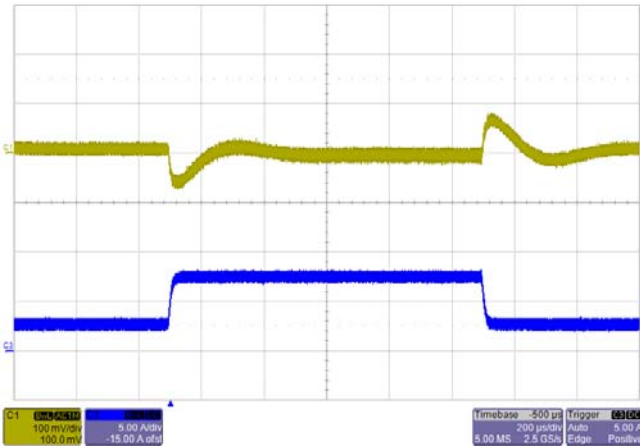

Transient Response $V_{IN}=5V$, Step from 2.5A~7.5A~2.5A,
 $C_o=220\mu F$
 Blue: Load Current Yellow: Output Ripple

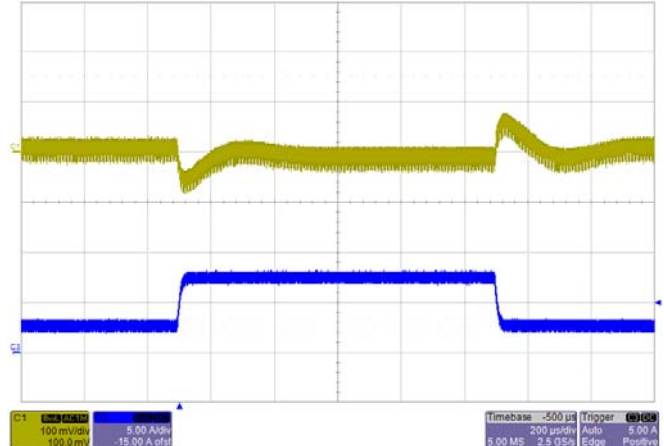

Transient Response $V_{IN}=12V$, Step from 2.5A~7.5A~2.5A,
 $C_o=220\mu F$
 Blue: Load Current Yellow: Output Ripple

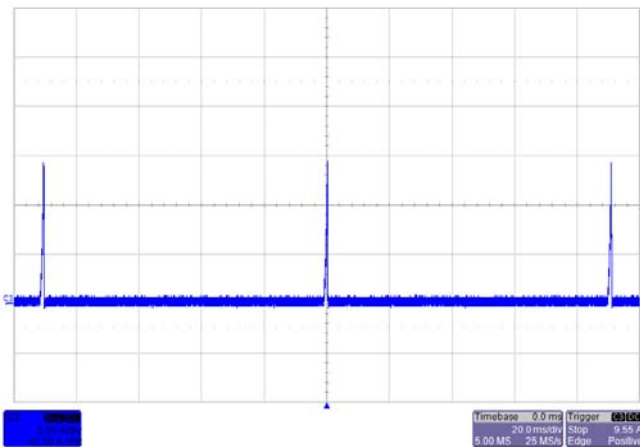

Short Circuit Protection, $V_{IN}=5V$

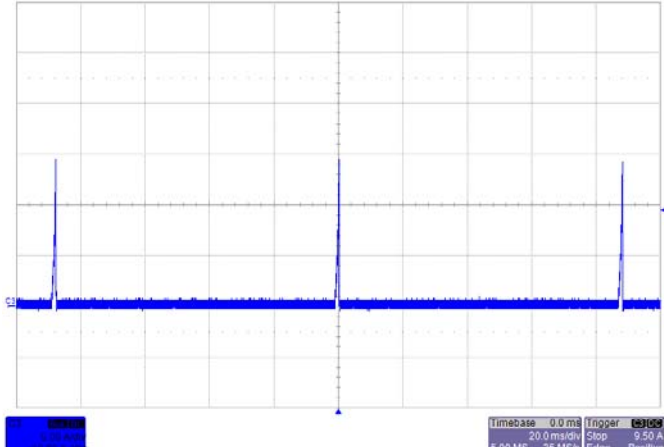

Short Circuit Protection, $V_{IN}=12V$

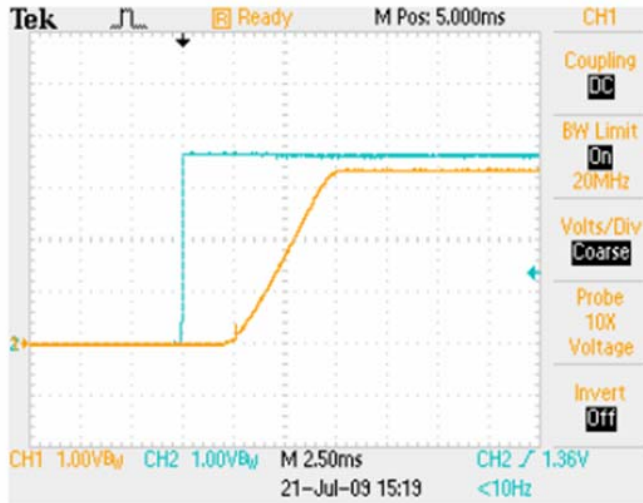

Power Up with ON/OFF Control, $V_{IN}=5V$
 Blue: ON/OFF Control Voltage Yellow: Output Voltage

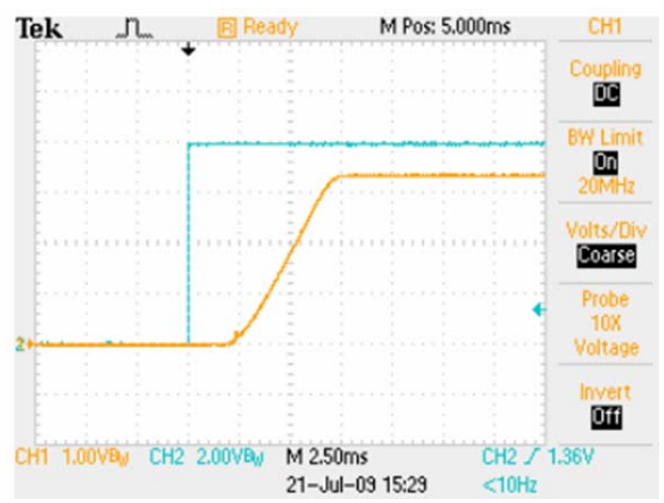

Power Up with ON/OFF Control, $V_{IN}=12V$
 Blue: ON/OFF Control Voltage Yellow: Output Voltage

MQ7250R

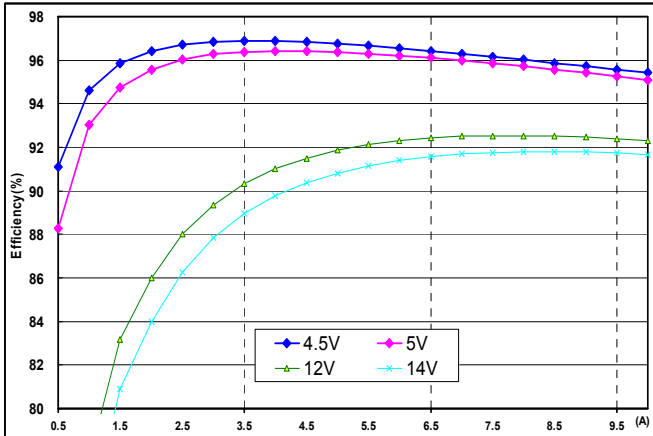

Efficiency vs. Load Current

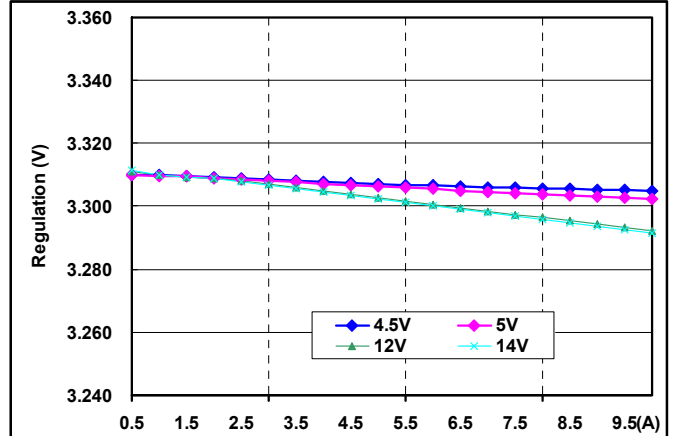

Regulation
Output voltage vs. Load Current

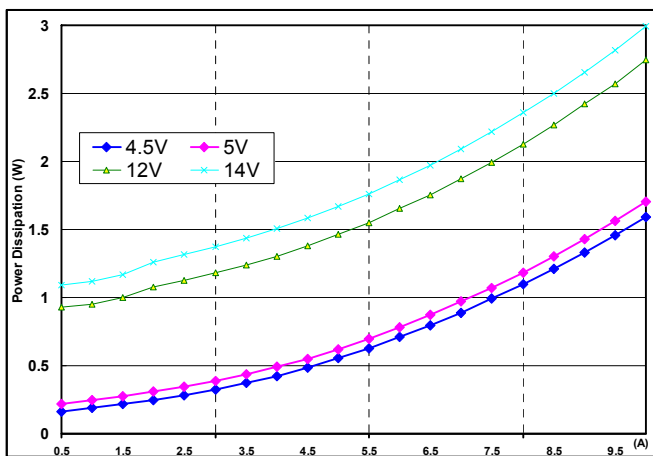

Power Dissipation vs. Load Current

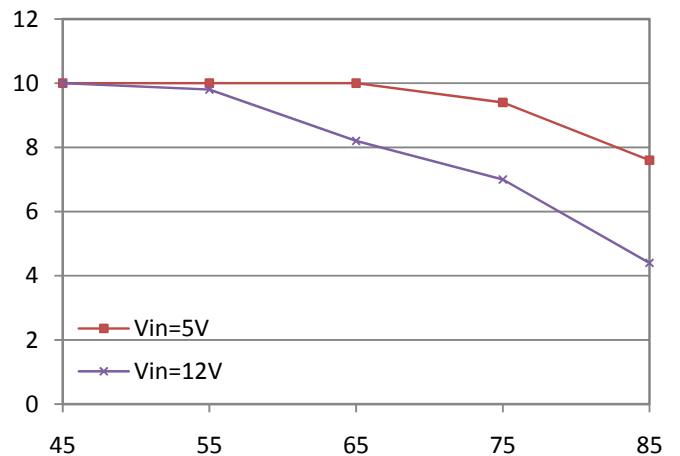

Output Current Derating

(Input filter:68uF/20V*3 TAN;
Output filter:227/10V*4 TAN+47uF/6.3V*1 (陶瓷))

Typical Characteristics—output adjusted to 5.0V

General conditions:

Input filter 22 μ F Ceramic + 100 μ F TAN (100m Ω ESR), Output filter 22 μ F Ceramic*2 + 100 μ F TAN (100m Ω ESR)*2

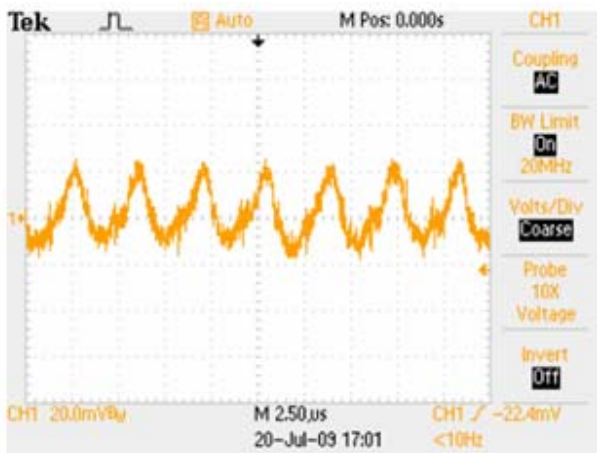

Noise $V_{IN}=12V$, $I_O=10A$, 5~20MHz Bandwidth

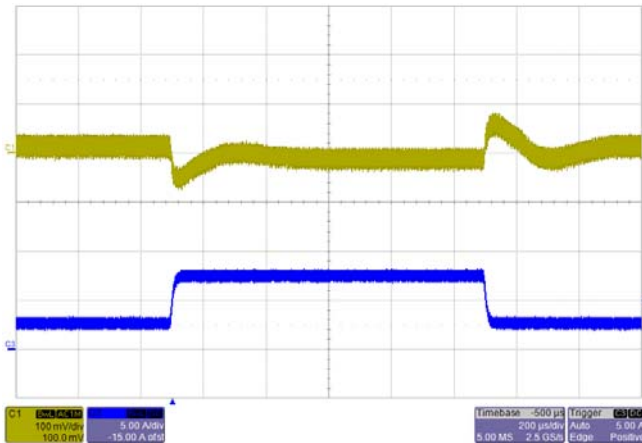

Transient Response $V_{IN}=12V$, Step from 2.5A~7.5A~2.5A, $C_O=220\mu F$

Blue: Load Current Yellow: Output Ripple

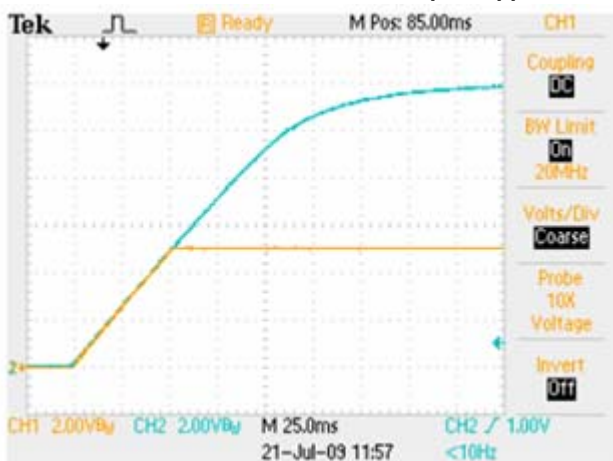

Power Up with EasyTrack™ Control $V_{Track}=12V$, $I_O=10A$
Blue: EasyTrack™ Control Voltage Yellow: Output Voltage

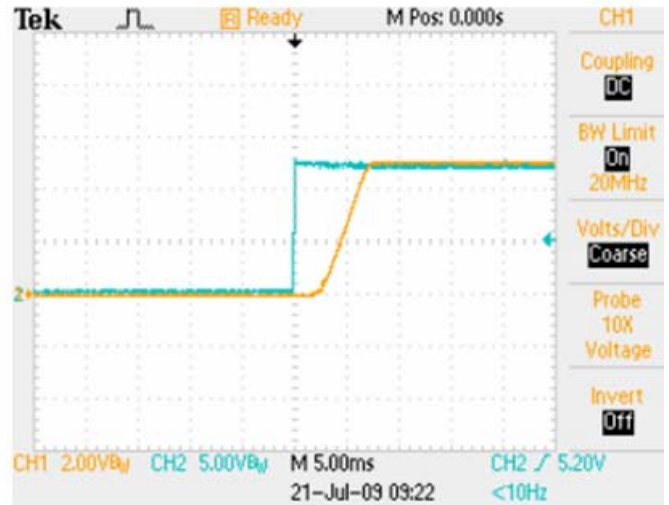

Start-up $V_{IN}=12V$, $I_O=10A$

Yellow: Output Voltage Blue: Input Voltage

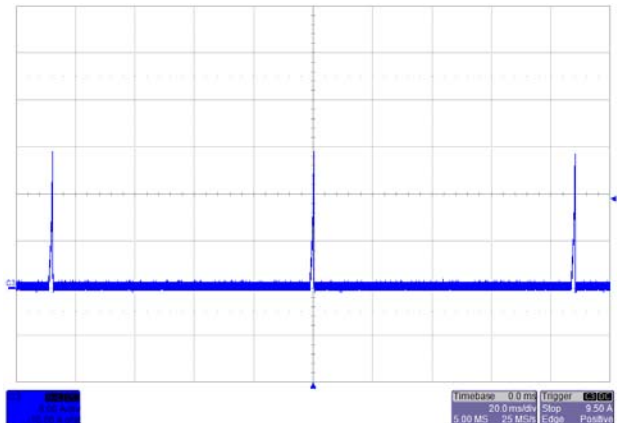

Short Circuit Protection, $V_{IN}=12V$

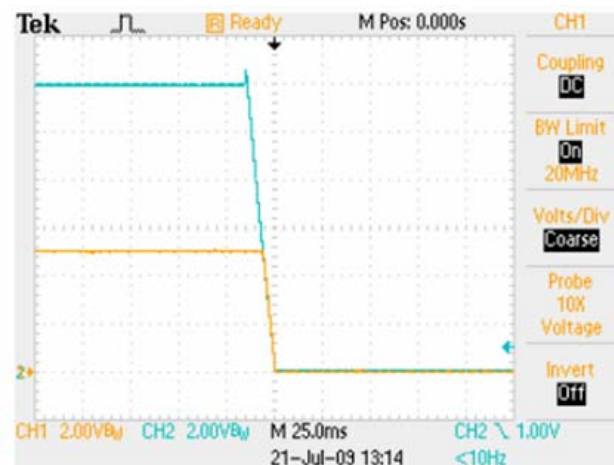

Power Down with EasyTrack™ Control $V_{Track}=12V$, $I_O=10A$
Blue: EasyTrack™ Control Voltage Yellow: Output Voltage

MQ7250R

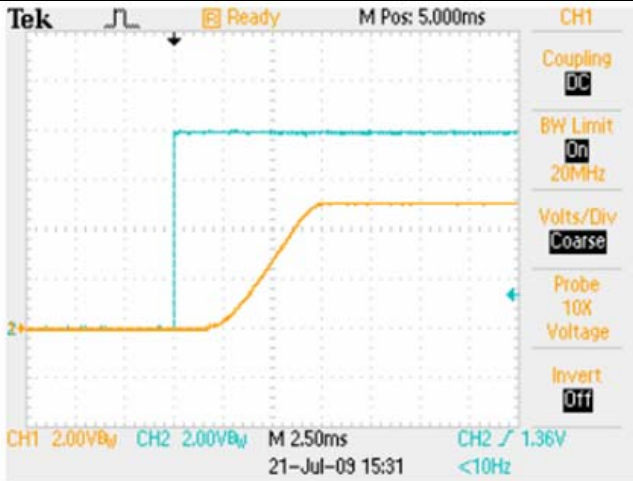

Power Up with ON/OFF Control, $V_{IN}=12V$
 Blue: ON/OFF Control Voltage Yellow: Output Voltage

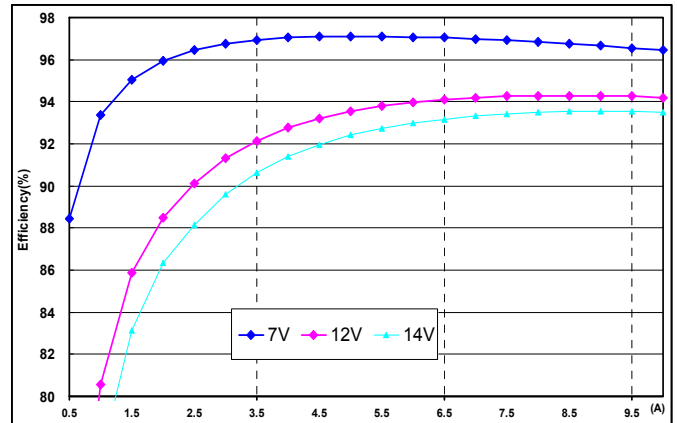

Efficiency vs. Load Current

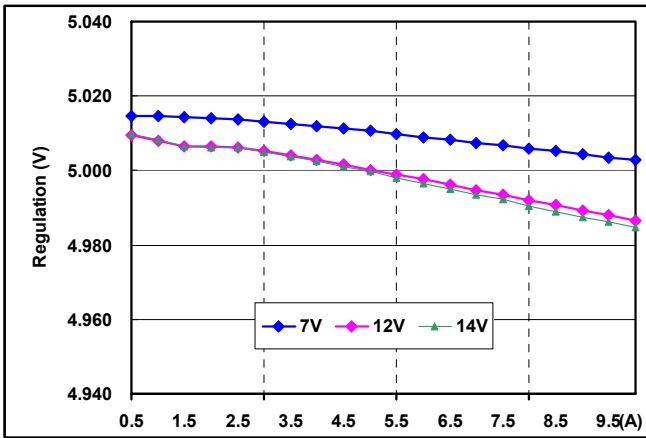

Regulation
 Output voltage vs. Load Current

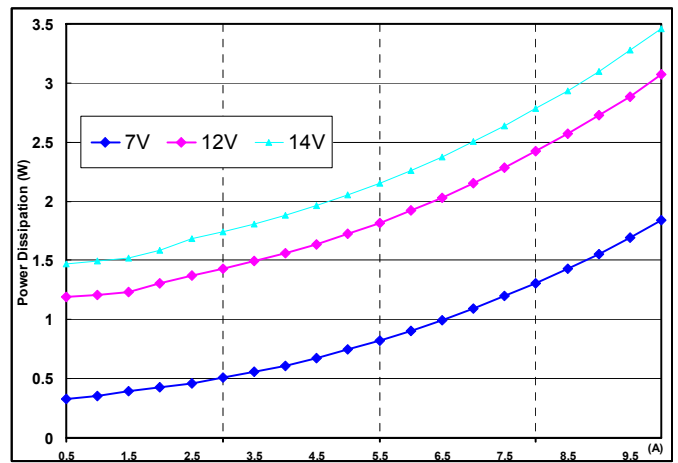

Power Dissipation vs. Load Current

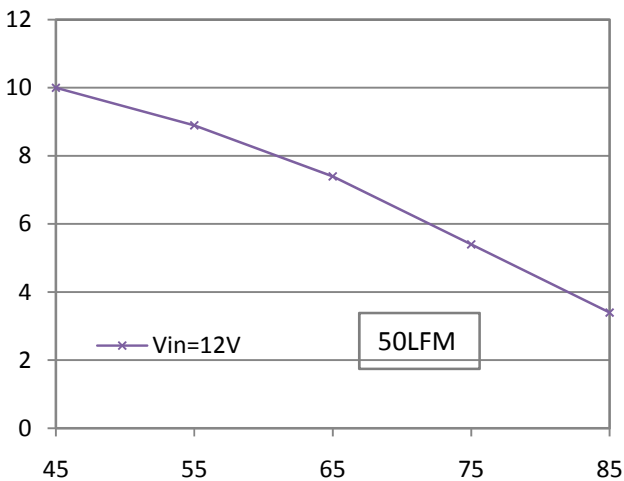

Output Current Derating

(Input filter: 68uF/20V*3 TAN;
 Output filter: 227/10V*4 TAN+47uF/6.3V*1 (陶瓷))

Typical Characteristics—output adjusted to 5.5V

Input filter:68uF/20V*3 TAN

Output filter:227/10V*4 TAN+47uF/6.3V*1 (陶瓷)

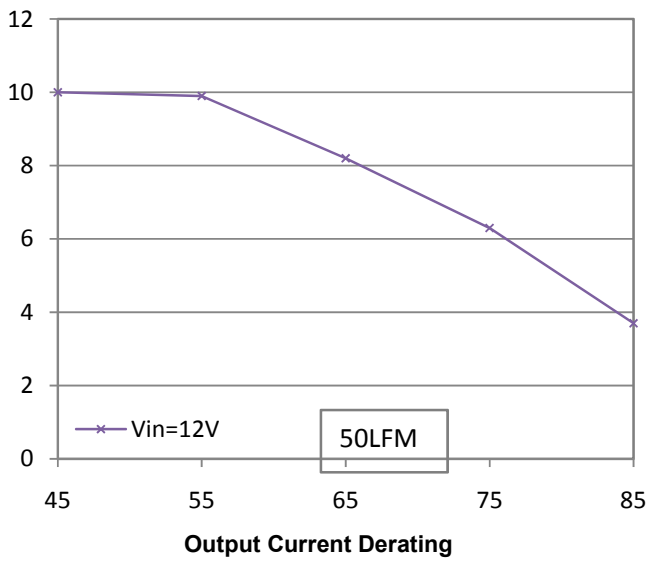

Recommended Pattern for "T" suffix

Dimensions are in mm (inches)

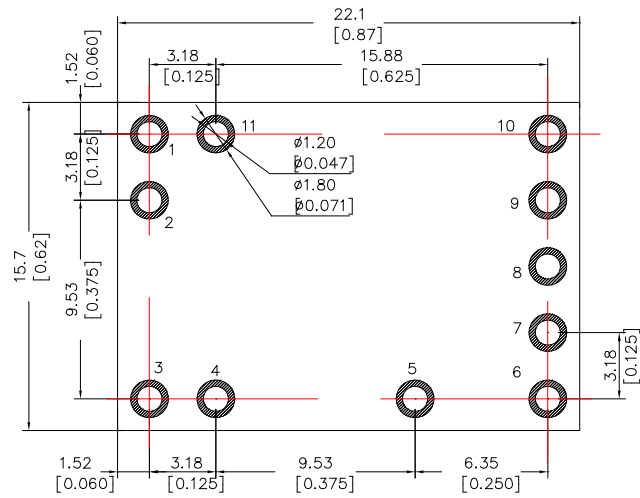

Component-side footprint

Recommended Pattern for "S" suffix

Dimensions are in mm (inches)

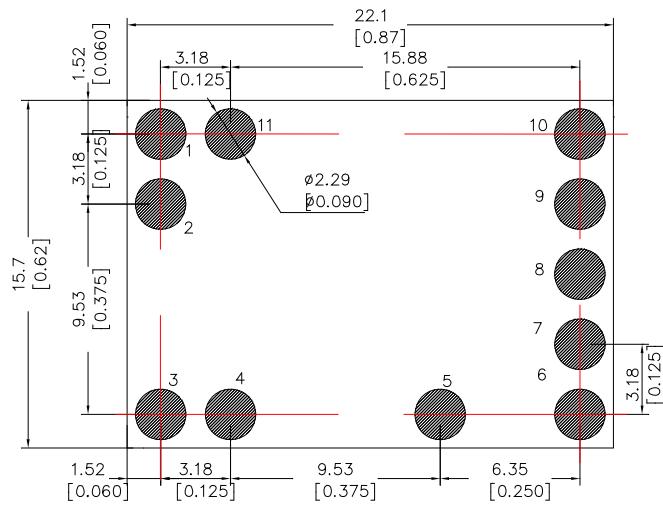

Component-side footprint

Application Notes