

MQ7230LA/BT12L, MQ7230LA/BT12W
Non-isolated 10~14VDC input, 0.8~1.8V/1.2~5.5V output, 6A DC-DC Converter

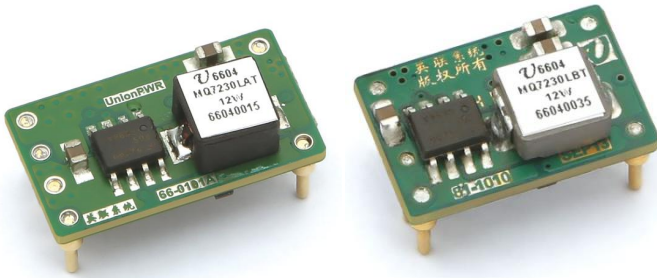

Features

- Wide operating voltage: 10V ~ 14V
- Output Voltage:
 - L: 0.8~1.8V
 - W: 1.2~5.5V
- Output Current up to 6A
- Output voltage ripple: 20mV_{PP}
- High Efficiency 93%
- Sequencing -- EZ-Tracking™ (A only)
- Overcurrent /shortcircuit protection
- Over-temperature protection
- Remote on/off control-Negative logic
- High reliability: designed to meet 5 million hour MTBF
- Minimal space on PCB:
 - MQ7230LA:
 - 22.1 mm x 12.6mm x 8.0 mm or
 - 0.87 in x 0.5 in x 0.31 in
 - MQ7230LB:
 - 18.9 mm x 12.6 mm x 6.4 mm or
 - 0.75 in x 0.5 in x 0.25 in
- No derating to +75°C, natural convection
- UL/IEC/EN60950 compliant
- RoHS Compliant

Applications

- Workstations, servers
- Desktop computers
- DSP applications
- Distributed power architectures
- Telecommunications equipment
- Data communications equipment
- Wireless communications equipment

Description

The MQ7230L/IBA Series Power Modules are non-isolated dc-dc converters that operate over a wide input voltage range of 8Vdc to 14Vdc and provide a precisely (2%) regulated dc output with industry standard PoLA pin out. Such a module is suitable to application with 10V or 14V power supply bus. The modules have a maximum output current rating of 6A at a typical full-load efficiency over 93%. Standard features include remote on/off with negative logic and output voltage trimmable, over-current protection, over-temperature protection.

MQ7230L/IBA can load 6A in a very small size. This improves PCB layout and system integration capability

***** **Typical Application Circuit** *****

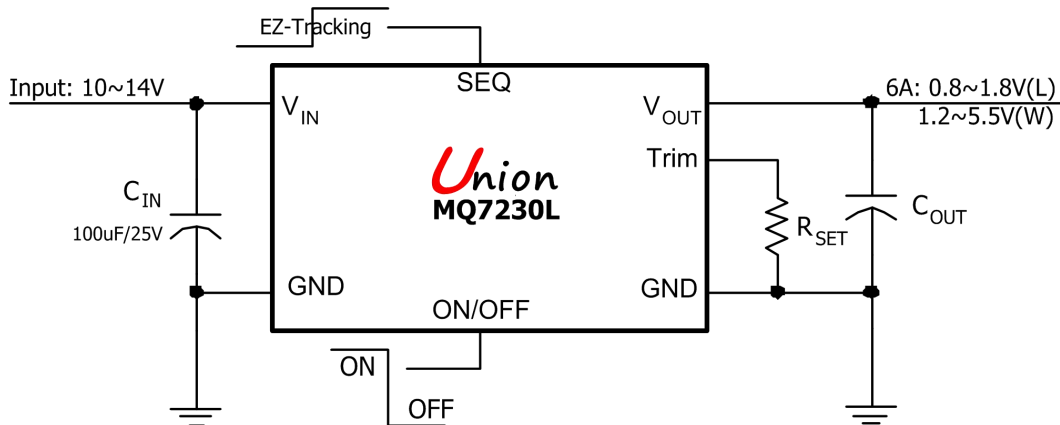

MQ7230LA/BT12L, MQ7230LA/BT12W

Performance Specifications (at TA=+25°C)

Model	Input V _{IN} Range (V)	I _{OUT} (A)	Trim Range (V)	Output Regulation		Efficiency (%)
				Line (%)	Load (%)	
MQ7230LAT12L	10~14	6	0.8V~1.8V	0.5	0.5	93
MQ7230LAT12W	10~14	6	1.2V~5.5V	0.5	0.5	93
MQ7230LBT12L	10~14	6	0.8V~1.8V	0.5	0.5	93
MQ7230LBT12W	10~14	6	1.2V~5.5V	0.5	0.5	93

Mechanical Specifications

Dimensions are in mm (inches)

Tolerances: x.x mm±0.5mm (x.xx in ±0.02 in);

x.xx mm±0.25mm (x.xxx in ±0.01 in)

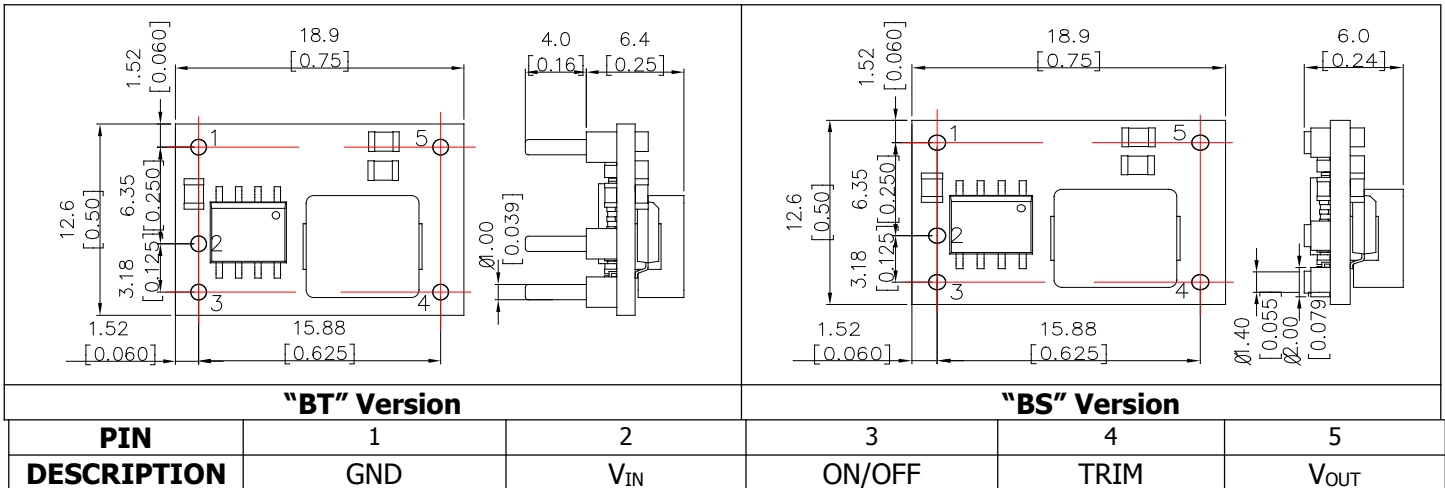
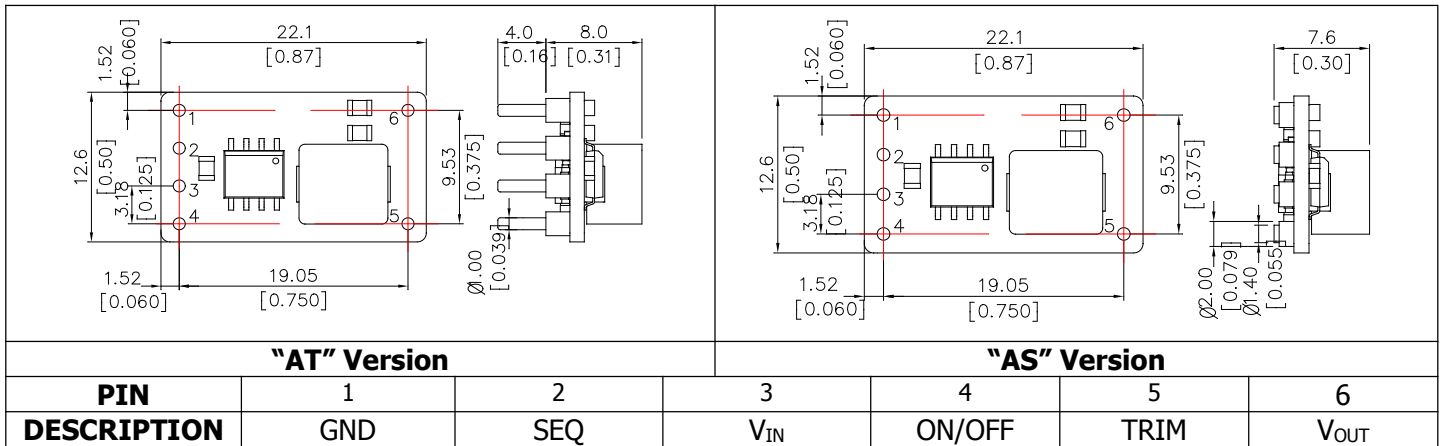

Ordering Information

MQ7230LAT12W

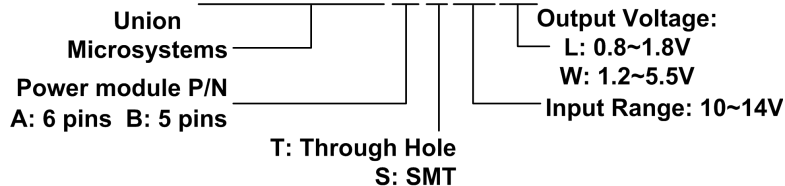

Absolute Maximum Ratings

Note: These are stress ratings. Exposure of devices to any of these conditions may adversely affect long-term reliability. Proper operation under conditions other than those listed in the Performance Specifications Table is not implied.

Parameter	Symbol	Min	Max	Unit
Input Voltage	V_{IN}	-0.3	16	V
Storage Temperature	T_{STG}	-40	125	°C

MQ7230L/IBA Electrical Specifications: ($T_A = +25^\circ\text{C}$, input voltage 12V, unless otherwise noted)

Parameter	Condition	Symbol	Min	Typ	Max	Unit
Input Voltage Range		V_{IN}	10		14	V
Output Current		I_o	0		6	A
Output Voltage Set point	100% load	ΔV_o	-2		+2	%
Temperature Regulation	$T_A = T_{A,MIN}$ To $T_{A,MAX}$	-		0.4		% $V_{O,SET}$
Output Trim Range	See Performance Specifications (from page 8~21)					
Line Regulation						
Load Regulation						
Output Ripple and Noise Voltage	$I_o = 5A, 0\sim 20\text{MHz}$ (Detail Please see Ripple Figures, Page 8~21)					
Transient Response						

General Specifications

Parameter	Condition	Symbol	Min	Typ	Max	Unit
Maximum Capacitive Load	5A resistive load + Aluminum capacitor			6600		μF
	5A resistive load + Sanyo POSCAP			2000		
Overcurrent Protection			6.5		10	A
Output short-circuit current (average)	All				2	A
Under Voltage Lockout Trip Level	Rising and falling V_{IN} , 3% hysteresis		7.8	9.3		V
Logic High (Module OFF)		V_{IH}			$V_{IN,MAX}$	V
Logic Low (Module ON)		V_{IL}	-0.7		0.3	V
Start-up Time	5A resistive load, no external output capacitors			2		mS
Switching Frequency		F_o		300		kHz
Operating Temperature	Natural convection, no forced air flow (with derating of $0.5\text{W}/^\circ\text{C}$ when $T_A \geq +55^\circ\text{C}$)		-40		85	°C
Vibration	3 Axes, 5 Min Each	10~55Hz, 0.35mm, 5g				
	3 Axes, 6 Times Each	Peak Deviation 300g, Settling Time 6mS				
MTBF		5,000,000				Hour

Test Configurations

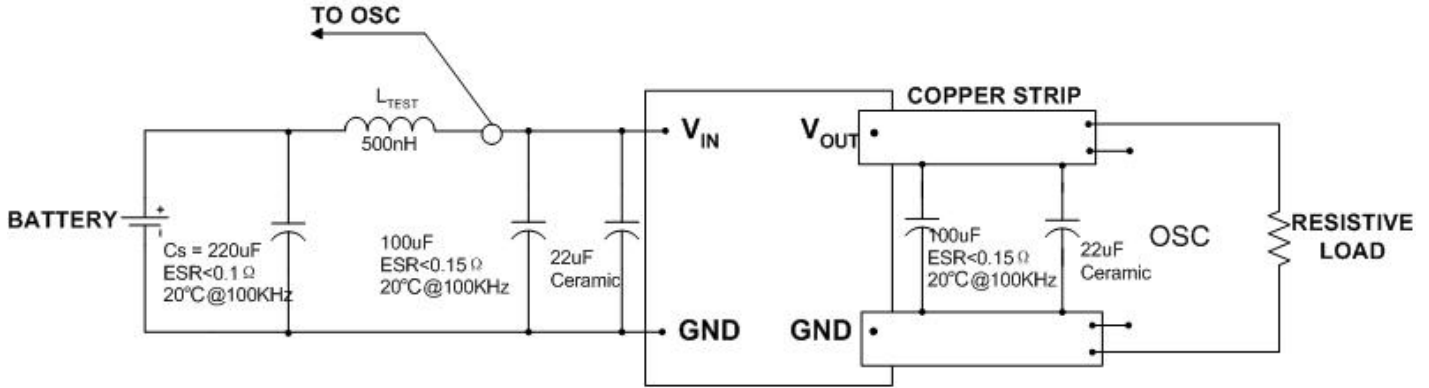

Test setup for input noise, output noise and ripple

Note:

Output noise is measured with 0.1 μ F ceramic capacitor connected at the output. OSC measurement should be made using a BNC socket. Position the load between 50mm and 75mm (2in. and 3in) from the tested module.

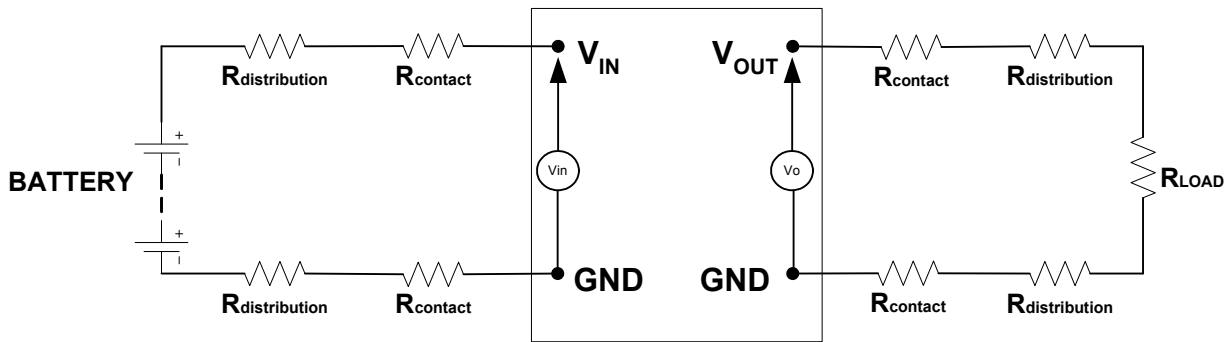

Test setup for efficiency

Note:

All voltage measurements must be taken at the module's terminals, as shown above. If sockets are needed, Kelvin connections are required at the module terminals to avoid measurement errors due to socket contact resistance.

Technical Notes

Input Voltage Range

The MQ7230L/IBA Series can be used in a wide variety of applications, esp. most of unregulated 12V intermediate power supply bus system. Its wide input voltage ranges can tolerate worst voltage drop from cheap isolated Brick-type Bus-converter, so it reduces total system cost on power supply.

Return Current Paths

The MQ7230L/IBA Series is non-isolated DC/DC converters. To the extent possible with the intent of minimizing ground loops, input and output return current should be directed through pin GND as short as possible.

I/O Filtering

All the specifications of the MQ7230L/IBA Series are tested and specified without output capacitors. However, certain input capacitors are necessary to improve the power modules' operating conditions and to reduce the ac impedance. For example, under some conditions, the power modules can't normally start up when fully loaded due to the high ac-impedance input source. External input capacitors serve primarily as energy-storage devices. They should be added close to the input pins of the MQ7230L/IBA and

selected for bulk capacitance (at appropriate frequencies), low ESR, and high rms-ripple-current ratings. All external capacitors should have appropriate voltage ratings. To reduce the amount of ripple current fed back to the input supply (input reflected-ripple current), an external L-C filter can be added with the inductance as close to the power module as possible.

MQ7230L/IBA's output ripple and transient response can be improved with the increasing output capacitance. When using output capacitors, take care that the total output capacitance does not exceed MQ7230L/IBA's Maximum Capacitive Load to avoid the module's protection condition in the start-up.

When an external L-C filter is added to reduce ripple on load, for best results, the filter components should be mounted close to the load circuit rather than the power module.

When testing the relationship between external capacitors and output voltage noise, the oscilloscope's probe should be applied to the module's end directly with scope probe ground less than 10mm in length.

Input Fusing

The MQ7230L/IBA Series is not internally fused. Certain applications and/or safety agencies may require the installation of fuses at the inputs of power conversion components. The selection of the fuses should conform to the following:

1. The fuse value should be selected to be greater than the maximum input current of the module which occurs at the minimum input voltage.
2. Use either slow-blow or normal-blow fuses.
3. Both input traces must be capable of carrying a current of 1.5 times the value of the fuse without opening.

Safety Considerations

MQ7230L/IBA's are non-isolated DC/DC converters. In general, all DC-DC's must be installed in compliance with relevant safety-agency specifications (usually UL/IEC/EN60950). In particular, for a non-isolated converter's output voltage to meet SELV (safety extra low voltage) requirements, its input must be SELV compliant. If the output needs to be ELV (extra low voltage), the input must be ELV.

Remote Sense

MQ7230L/IBA Power Modules with suffix "S" offer an output sense function on pin 3. The sense function enables point-of-use regulation for overcoming moderate IR drops in conductors and/or cabling. The sense line carries very little current and consequently requires a minimal cross-sectional-area conductor. As such, it is not a low-impedance point and must be treated with care in layout and cabling. Sense lines should be run adjacent to signals (preferably ground).

Use of trim and sense functions can cause the output voltage to increase, thereby increasing output power beyond the MQ7230L/IBA's specified rating. Therefore:

$$V_{OUT} \text{ (at pins)} \times I_{OUT} \leq P \text{ (rated output power)}$$

Note: If devices have the +Sense pin (pin3) installed and the sense function is not used for remote regulation, +Sense (pin3) must be tied to +Output (pin4) at the DC/DC converter pins.

ON/OFF Control

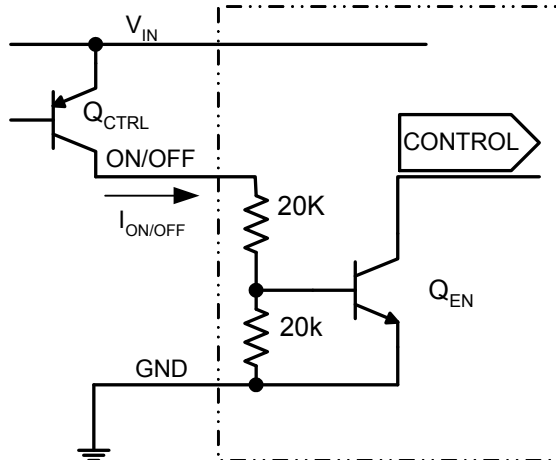

Fig1a. Remote ON/OFF Implementation with pull-up pnp transistor

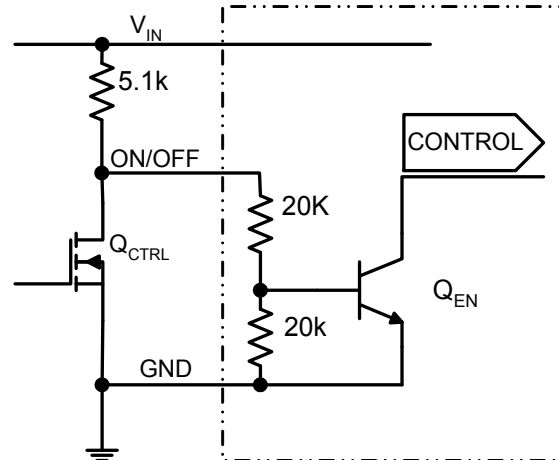

Fig1b. Remote ON/OFF Implementation with Open Collector/Drain transistor

The MQ7230L/IBA power modules feature an On/Off pin for remote On/Off operation. If not using the remote On/Off pin, leave the pin open (module will be On). The On/Off pin signal (V_{on/Off}) is referenced to ground. To switch module on and off using remote On/Off, connect an open collector pnp transistor between the On/Off pin and the V_{IN} pin (See Figure 1a). During a logic-low when the transistor Q_{EN} inside power module is in the Off state, the power module is ON and the maximum V_{on/off} of the module is

MQ7230LA/BT12L, MQ7230LA/BT12W

0.4 V. The maximum allowable leakage current of Q_{EN} when $V_{on/off} = 0.4V$ and $V_{IN} = 5.5V$ is 100 μ A. During a logic-high when Q_{EN} is in the active state, the power module is OFF. During this state $V_{On/Off} = 2.5V$ to 5.5V and the maximum $I_{On/Off} = 1mA$.

Remote On/Off can also be implemented using open collector/ drain logic devices with an external pull-up resistor. Figure 1b shows the circuit configuration using this approach. 5.1k (+/- 5%) pull-up resistor is for proper operation of module function over the entire temperature range.

Output Overvoltage Protection

MQ7230L/IBA Series products do not incorporate output overvoltage protection. If the operating circuit requires protection against abnormal output voltage, voltage-limiting circuitry must be provided external to the power module.

Output Overcurrent Protection (OCP)

MQ7230L/IBA incorporates overcurrent and short circuit protection. If the load current exceeds the overcurrent protection setpoint, the MQ7230L/IBA's internal overcurrent-protection circuitry immediately turns off the module, which then goes into Hiccup mode. The unit operates normally once the output current is brought back into its specified range. The typical average output current during hiccup is less than 2A.

Caution: Be careful never to operate MQ7230L/IBA in a "heavy overload" condition that is between the rated output current and the overcurrent protection setpoint. This can cause permanent damage to the components.

Overtemperature Protection (OTP)

To ensure MQ7230L/IBA's reliability and avoid damaging its internal components, MQ7230L/IBA incorporates overtemperature protection circuit. When the temperature of the PCB is above 130°C, the overtemperature protection circuit will be enabled and the module will stop working. when the temperature of the temperature-testing component is below about 80°C, the overtemperature protection circuit will release and the module will automatically recover from shutdown. To avoid permanently damaging components, the surface temperature of MQ7230L/IBA's power components, esp. of the MOSFET should be ensured below 130°C.

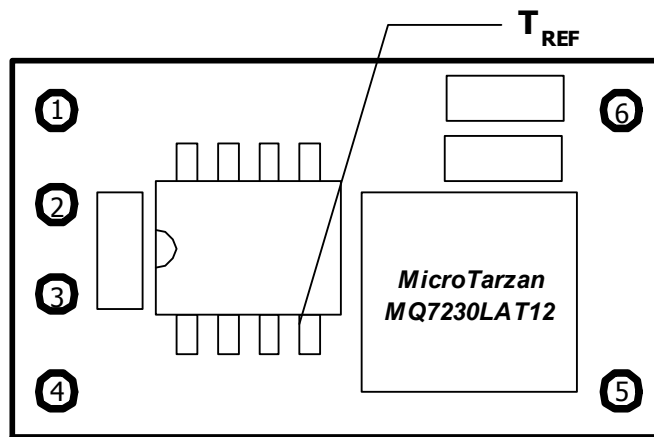

Fig2, Temperature Reference Point

Note: The overtemperature protection may be issued when MQ7230L/IBA operates in a "heavy overload" condition for a long time. Thus, the air flow should be improved.

Output Voltage Trimming

MQ7230L/IBA's output voltage can be trimmed in certain ranges. Figure 3 shows the circuit used to program output voltage. See Performance Specifications for allowable trim ranges in detail. Also customized products are available.

Trim with external resistor (Fig3), the equation as below:

$$\text{for MQ7230LA/BT12L: } R_{TRIM} = \frac{8000}{V_o - 0.8} - 7870$$

$$\text{for MQ7230LA/BT12W: } R_{TRIM} = \frac{8000}{V_o - 1.2} - 1820$$

Resistor values are in Ω ; V_O is desired output voltage.
For examples, to trim output to 1.5V, then

$$\text{for MQ7230LA/BT12L: } R_{TRIM} = \frac{8000}{1.5 - 0.8} - 7870 = 3558$$

$$\text{for MQ7230LA/BT12W: } R_{TRIM} = \frac{8000}{1.5 - 1.2} - 1820 = 24847$$

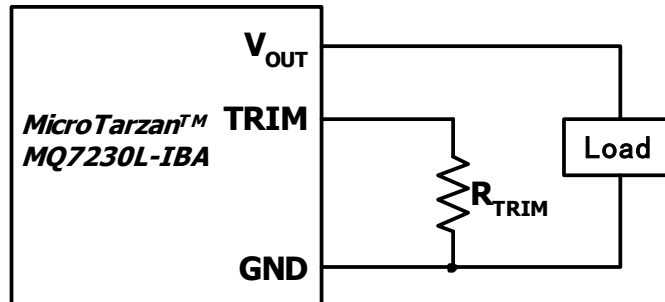

Fig3. Circuit configuration for programming output voltage using external resistor

For most common voltages, the required Trim resistors are as Table 1 and Table 2.

Table 1, Preferred R_{TRIM} Values for most voltages of MQ7230LA/BT12L

Desired Voltages (V)	R_{TRIM} (k Ω)
0.8	OPEN
1.0	32.4
1.2	12.1
1.5	3.57
1.8	0.13

Table 2, Preferred R_{TRIM} Values for most voltages of MQ7230LA/BT12W

Desired Voltages (V)	R_{TRIM} (k Ω)
1.2	OPEN
1.5	24.3
1.8	11.5
2.5	4.32
3.3	2.00
5.0	0.28

EZ-Track ("A" only)

1. The Track pin voltage must be allowed to rise above the modules' set-point voltage before the module can regulate at its adjusted set-point voltage;
2. The *EZ-Track* function will track almost any voltage ramp during power up, and is compatible with ramp speeds of up to 1V/ms;
3. The module will not follow a voltage at its Track control input until it has completed its soft-start initialization. This takes about 10ms from the time that the module has sensed that a valid voltage has been applied its input. During this period, it is recommended that the Track pin be held at ground potential;
4. The absolute maximum voltage that may be applied to the Track pin is V_{in} ;
5. The module is capable of both sinking and sourcing current when following a voltage at its Track pin. Therefore startup into an output pre-bias is not supported during *EZ-Track* control;
6. The *EZ-Track* function can be disabled by connecting the Track pin to the input voltage (V_{in}). With *EZ-Track* disabled, the output voltage will rise at a quicker and more linear rate after input power is applied.

Typical Characteristics – output adjusted to 1.2V

General conditions:

Input filter : Input filter 330uF/25V*2 Electrolytic Cap

Output filter: 270uF/25V*1 Solid Electrolytic Cap+1210-476/16V Ceramic Cap

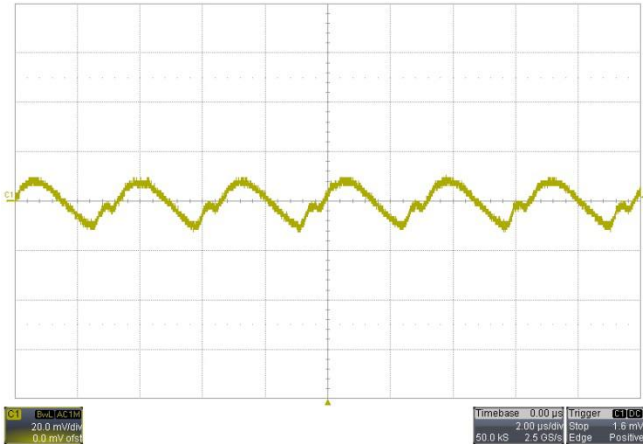

Noise $V_{IN}=12V$, $I_o=6A$, 5~20MHz Bandwidth

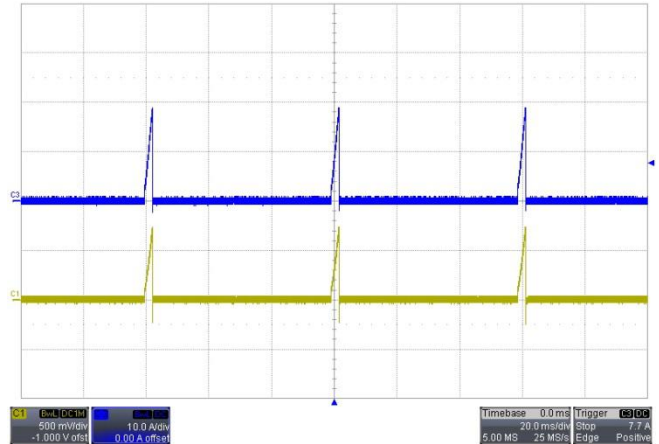

Short-Circuit Output $V_{IN}=12V$

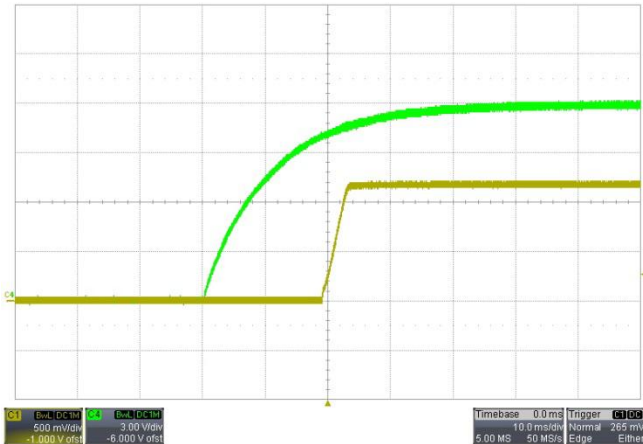

Start-up $V_{IN}=12V$, $I_o=6A$

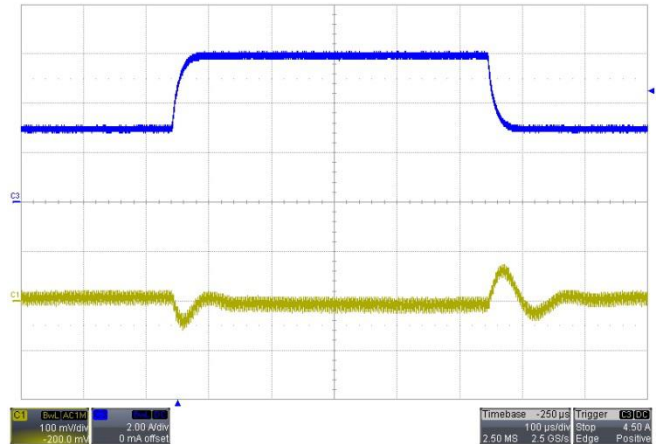

Transient Response $V_{IN}=12V$, Step from 3A~6A~3A



Start-up* $V_{IN}=12V$, $I_o=6A$

Output filter 90*22µF Ceramic + 100µF TAN (150mΩ ESR)

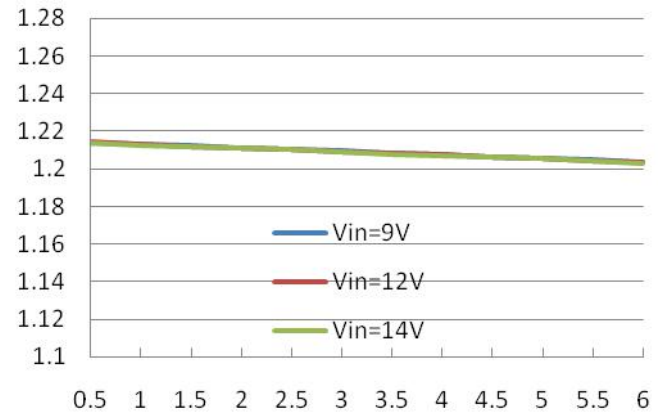

**Regulation
Output voltage vs. Load Current**

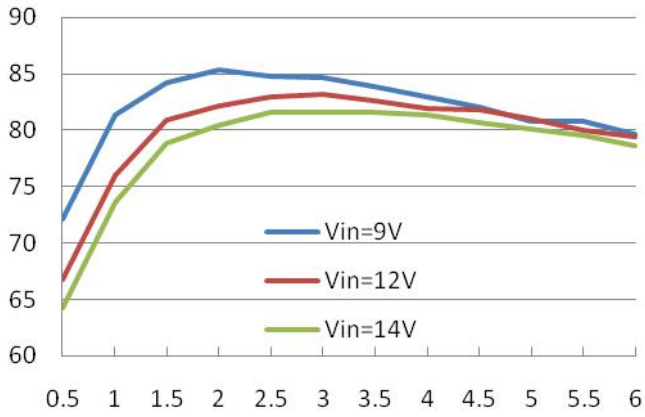

Efficiency

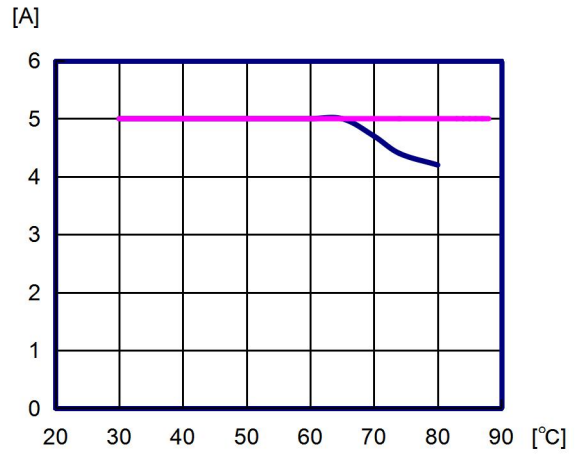

Output Current Derating (Load Current vs. Ambient Temperature (T_{REF} , See Page 6)), $V_{IN}=12V$

Typical Characteristics – output adjusted to 1.5V

General conditions:

Input filter : Input filter 330uF/25V*2 Electrolytic Cap

Output filter: 270uF/25V*1 Solid Electrolytic Cap+1210-476/16V Ceramic Cap

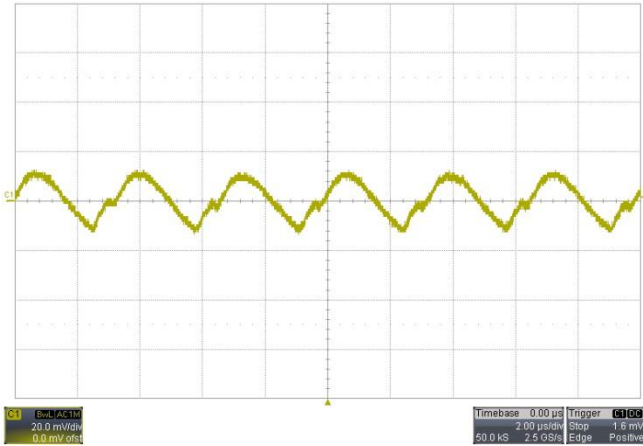

Noise $V_{IN}=12V$, $I_O=6A$, 5~20MHz Bandwidth

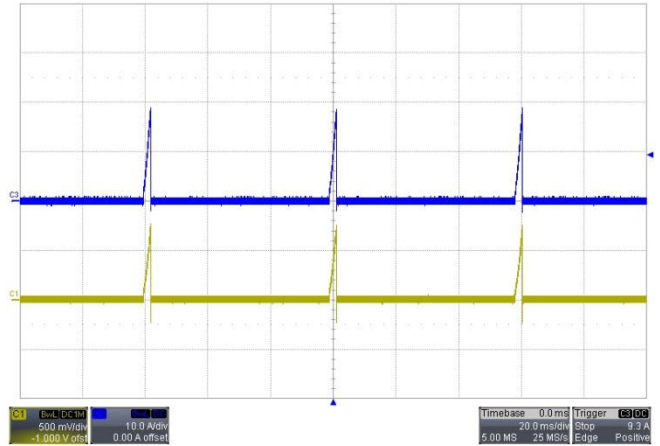

Short-Circuit Output $V_{IN}=12V$

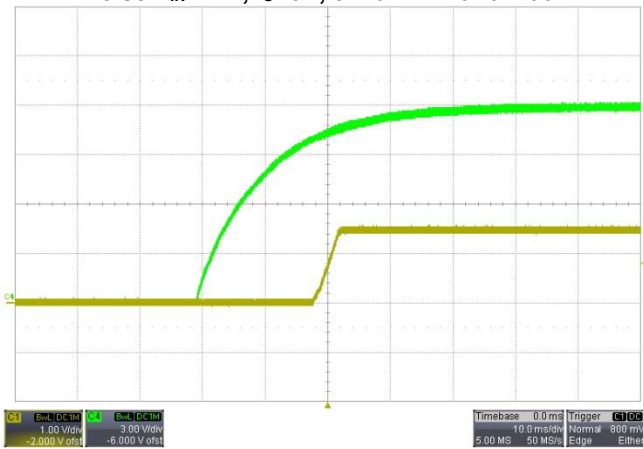

Start-up $V_{IN}=12V$, $I_O=6A$

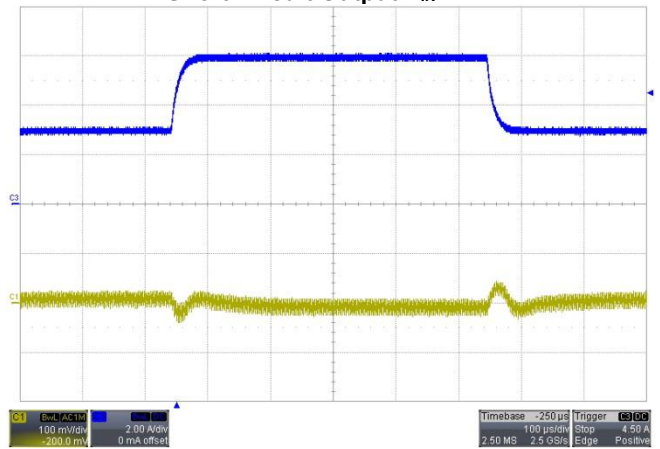

Transient Response $V_{IN}=12V$, Step from 3A~6A~3A



Start-up* $V_{IN}=12V$, $I_O=6A$

Output filter 90*22µF Ceramic + 100µF TAN (150mΩ ESR)

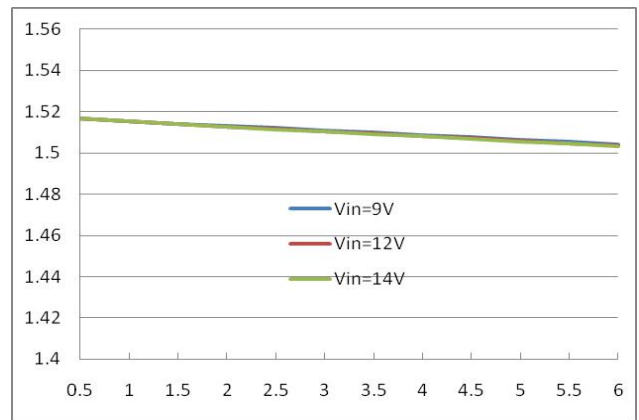

Regulation Output voltage vs. Load Current

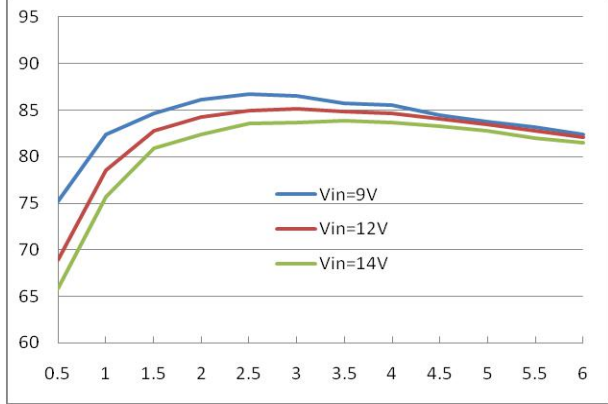

Efficiency

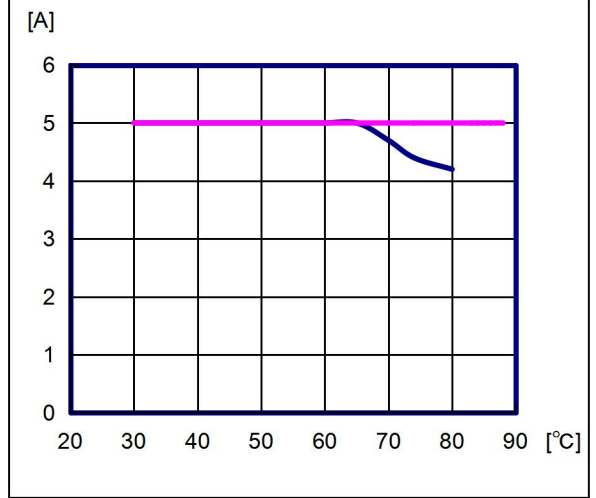

Output Current Derating (Load Current vs. Ambient Temperature (T_{REF} , See Page 6)), $V_{IN}=12V$

Typical Characteristics – output adjusted to 1.8V

General conditions:

Input filter : Input filter 330uF/25V*2 Electrolytic Cap

Output filter: 270uF/25V*1 Solid Electrolytic Cap+1210-476/16V Ceramic Cap

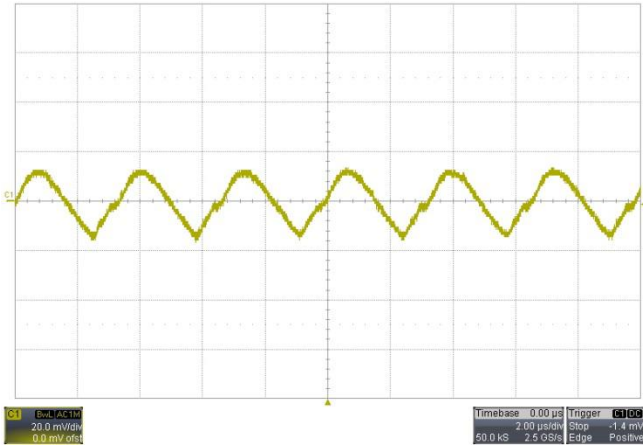

Noise $V_{IN}=12V, I_o=6A, 5\sim 20MHz$ Bandwidth

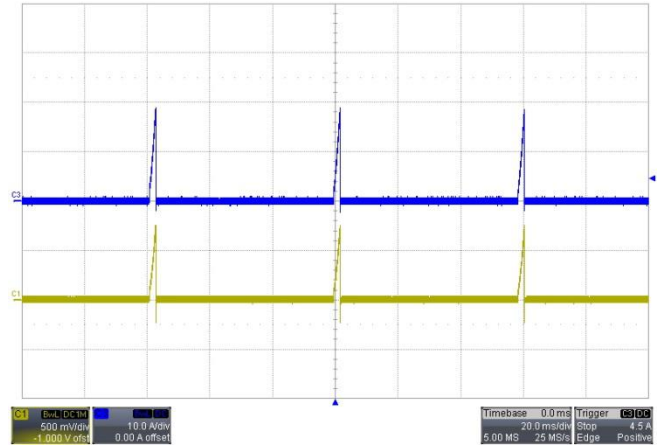

Short-Circuit Output $V_{IN}=12V$

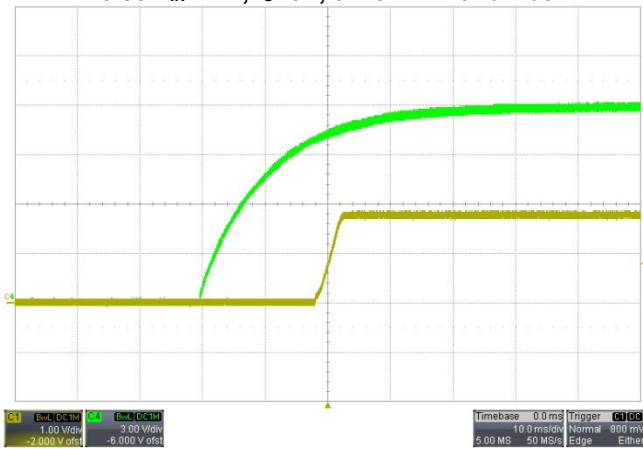

Start-up $V_{IN}=12V, I_o=6A$

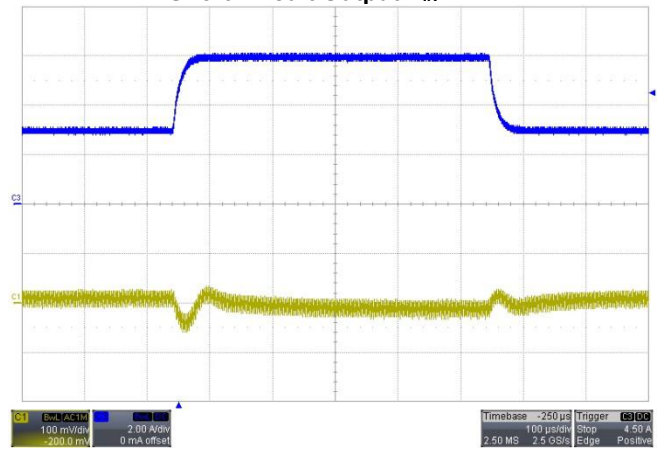

Transient Response $V_{IN}=12V, \text{Step from } 3A\sim 6A\sim 3A$



Start-up* $V_{IN}=12V, I_o=6A$

Output filter 90*22µF Ceramic + 100µF TAN (150mΩ ESR)

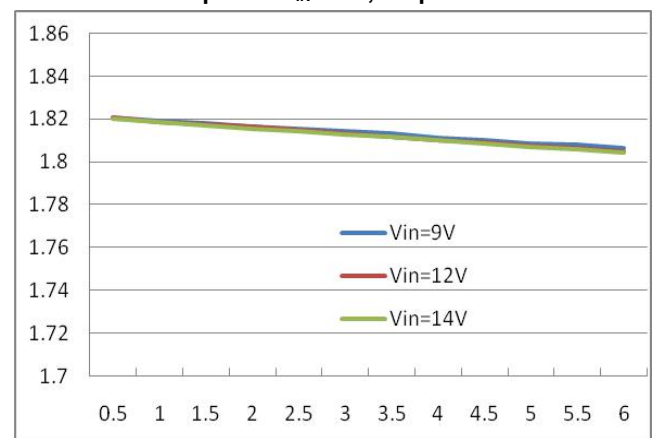

**Regulation
Output voltage vs. Load Current**

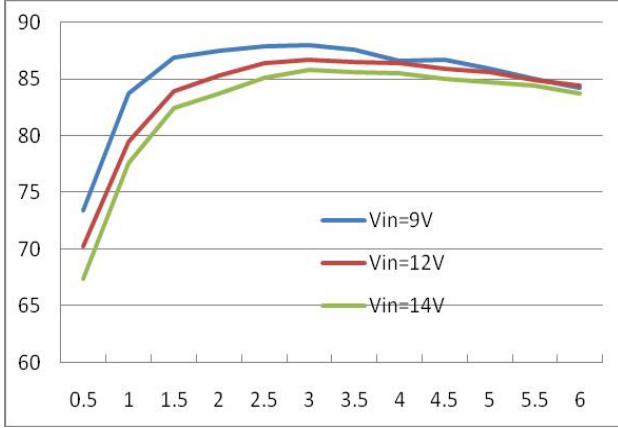

Efficiency

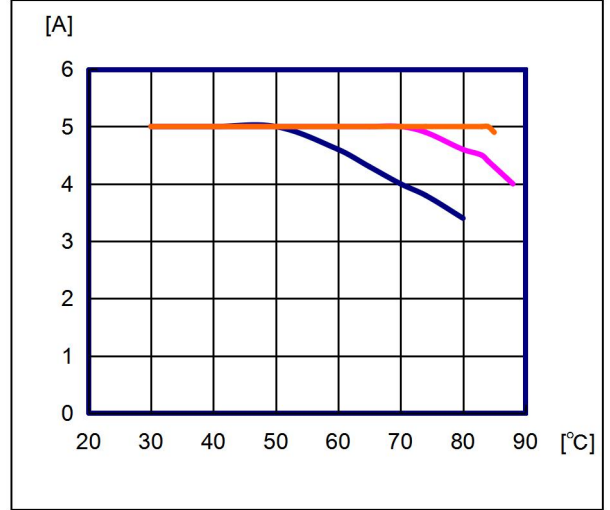

Output Current Derating (Load Current vs. Ambient Temperature (T_{REF} , See Page 6)), $V_{IN}=12V$

Typical Characteristics – output adjusted to 2.5V

General conditions:

Input filter : Input filter 330uF/25V*2 Electrolytic Cap

Output filter: 270uF/25V*1 Solid Electrolytic Cap+1210-476/16V Ceramic Cap

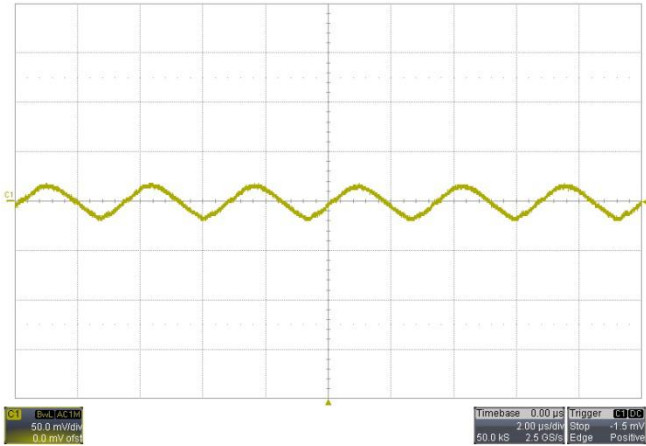

Noise $V_{IN}=12V$, $I_O=6A$, 5~20MHz Bandwidth

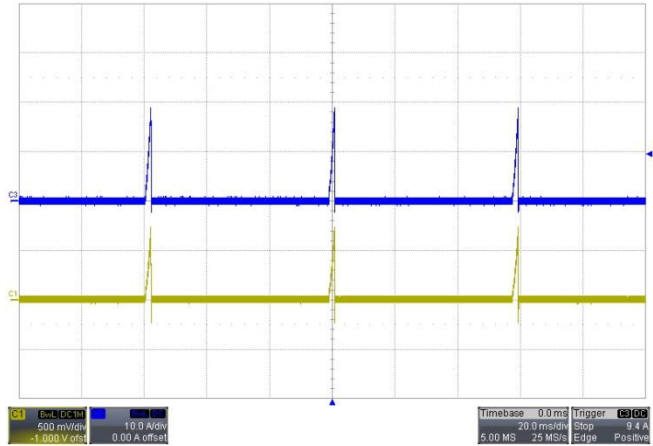

Short-Circuit Output $V_{IN}=12V$

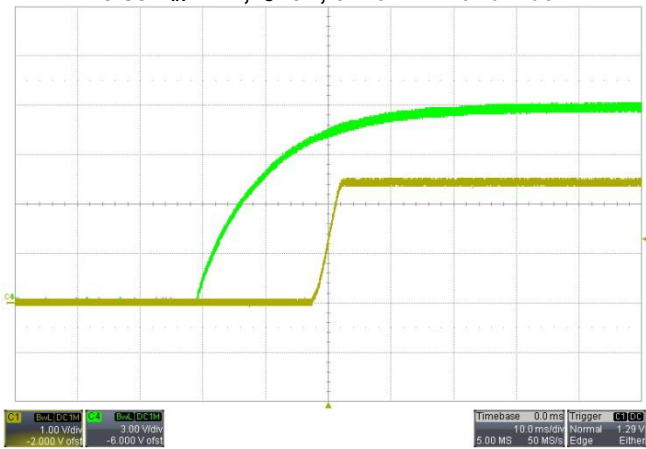

Start-up $V_{IN}=12V$, $I_O=6A$

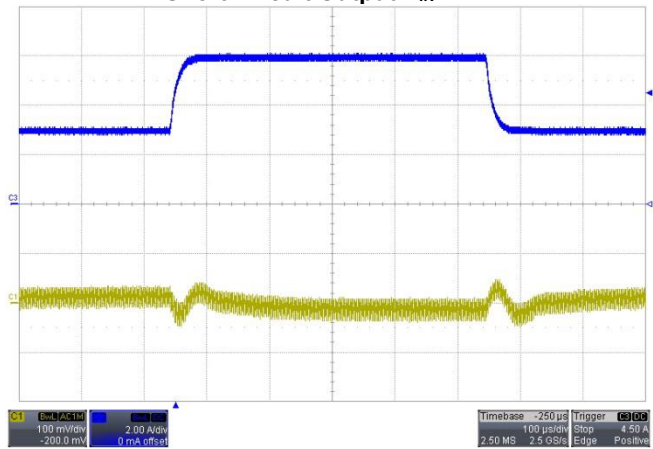

Transient Response $V_{IN}=12V$, Step from 3A~6A~3A



**Start-up* $V_{IN}=12V$, $I_O=6A$
Output filter 90*22μF Ceramic + 100μF TAN (150mΩ ESR)**

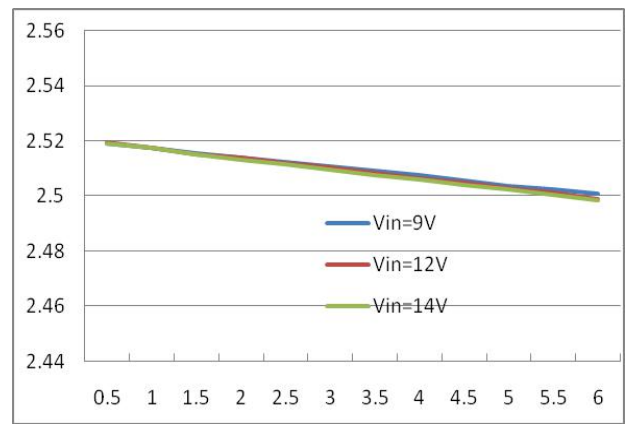

**Regulation
Output voltage vs. Load Current**

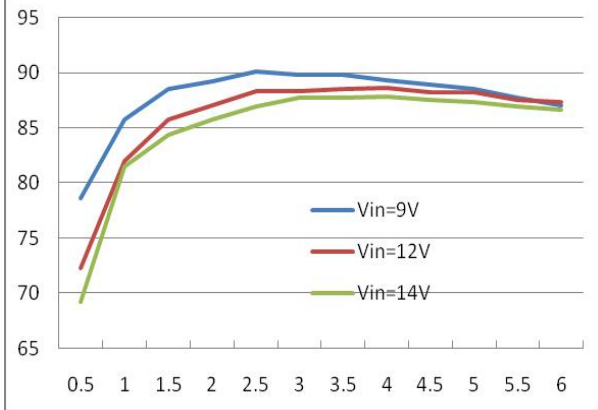

Efficiency

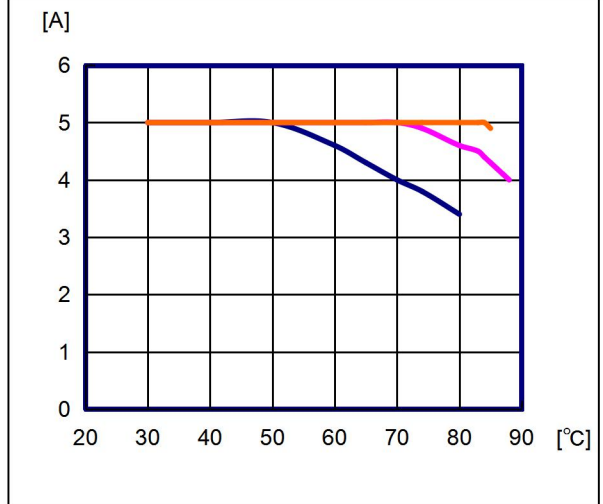

Output Current Derating (Load Current vs. Ambient Temperature (T_{REF} , See Page 6)), $V_{IN}=12V$,

Typical Characteristics – output adjusted to 3.3V

General conditions:

Input filter : Input filter 330uF/25V*2 Electrolytic Cap

Output filter: 270uF/25V*1 Solid Electrolytic Cap+1210-476/16V Ceramic Cap

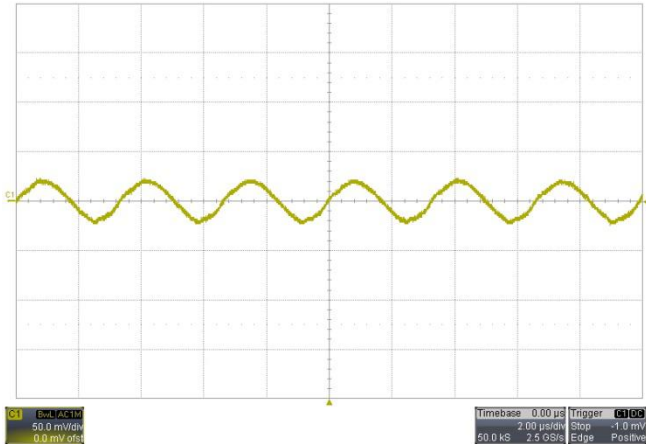

Noise $V_{IN}=12V$, $I_O=6A$, 5~20MHz Bandwidth

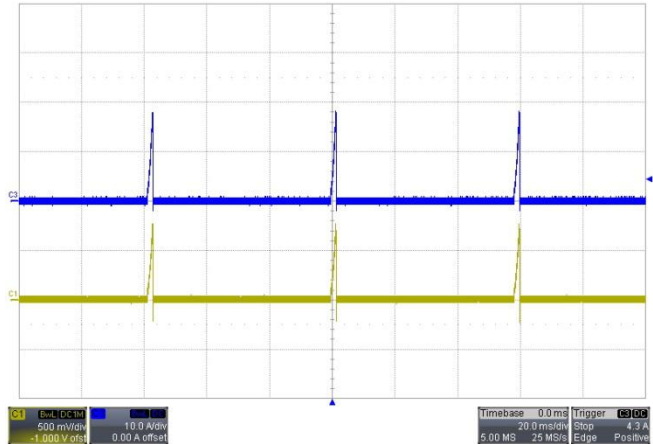

Short-Circuit Output $V_{IN}=12V$

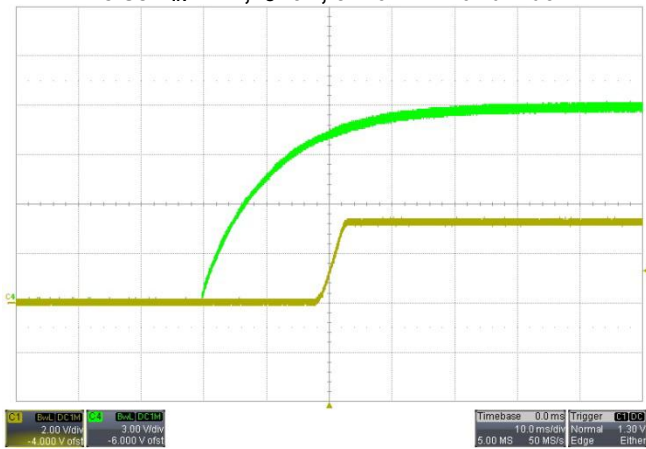

Start-up $V_{IN}=12V$, $I_O=6A$

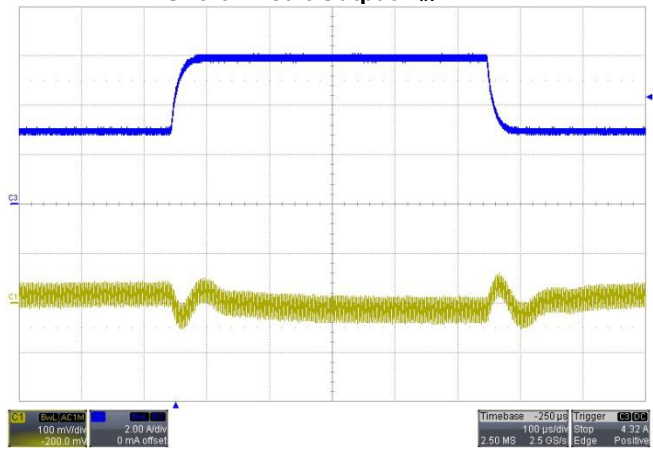

Transient Response $V_{IN}=12V$, Step from 3A~6A~3A



Start-up* $V_{IN}=12V$, $I_O=6A$

Output filter 90*22µF Ceramic + 100µF TAN (150mΩ ESR)

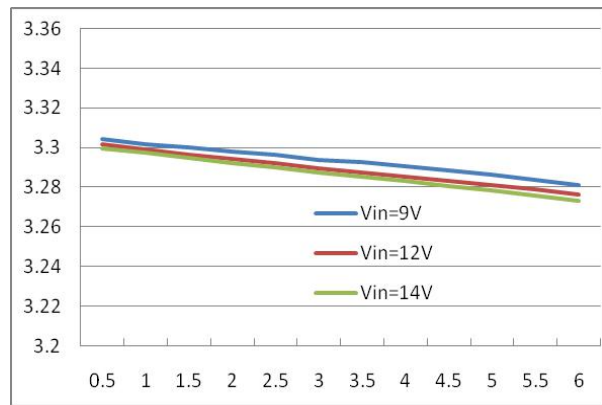

Regulation
Output voltage vs. Load Current

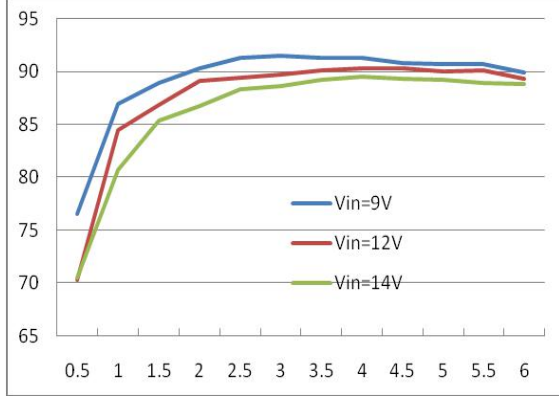

Efficiency

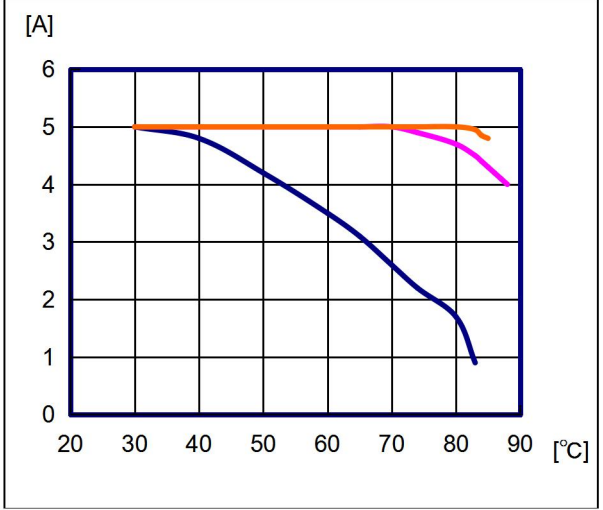

Output Current Derating (Load Current vs. Ambient Temperature (T_{REF} , See Page 6)), $V_{IN}=12V$,

Typical Characteristics – output adjusted to 5.0V

General conditions:

Input filter : Input filter 330uF/25V*2 Electrolytic Cap

Output filter: 270uF/25V*1 Solid Electrolytic Cap+1210-476/16V Ceramic Cap

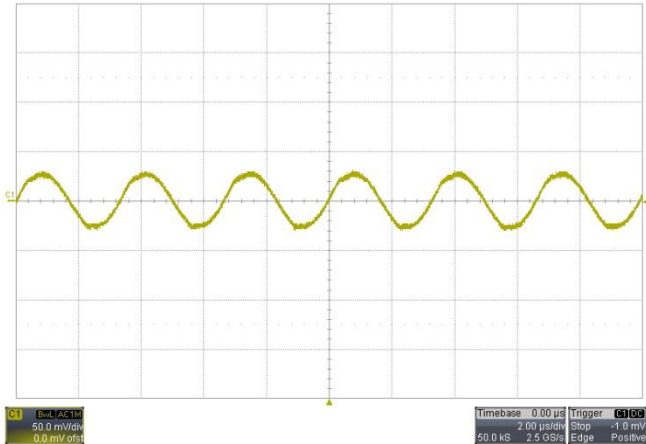

Noise $V_{IN}=12V$, $I_O=6A$, 5~20MHz Bandwidth

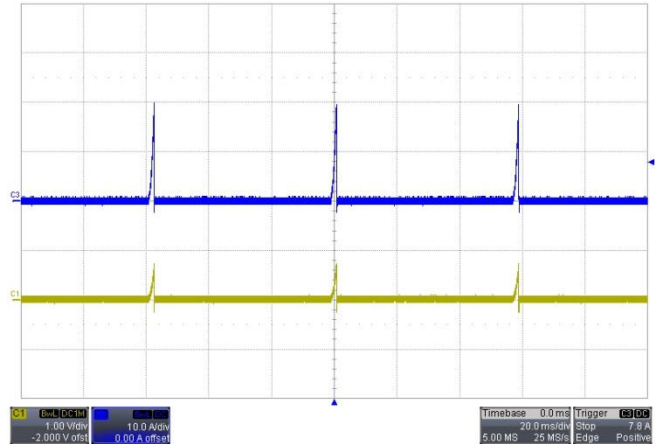

Short-Circuit Output $V_{IN}=12V$

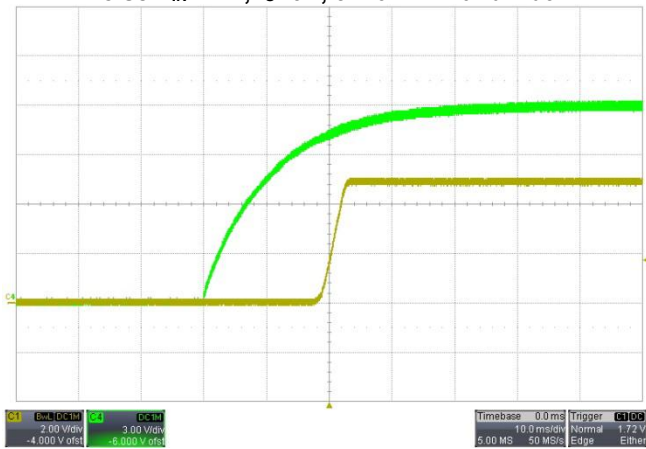

Start-up $V_{IN}=12V$, $I_O=6A$

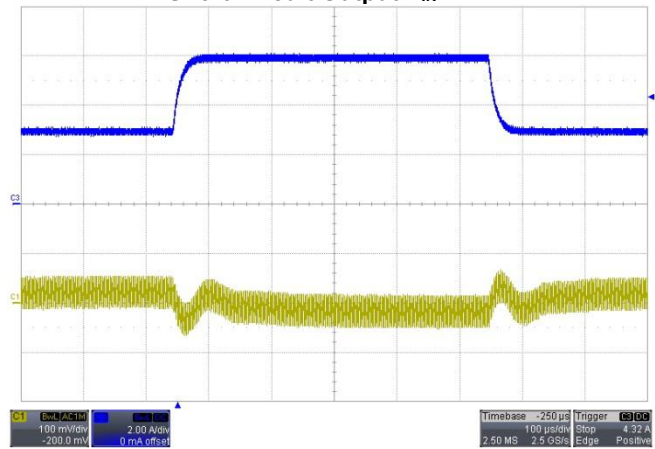

Transient Response $V_{IN}=12V$, Step from 3A~6A~3A



Start-up $V_{IN}=12V$, $I_O=6A$

Output filter 90*22μF Ceramic + 100μF TAN (150mΩ ESR)

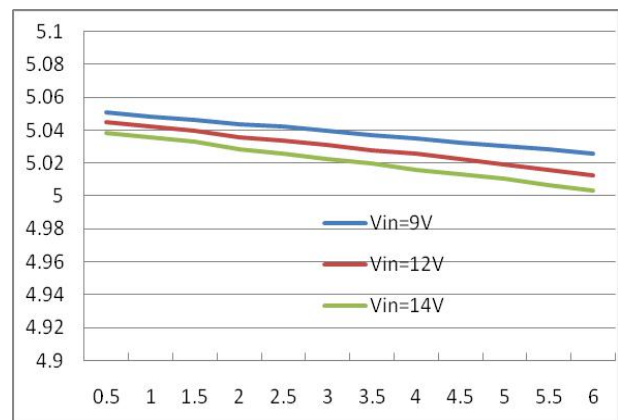

Regulation Output voltage vs. Load Current

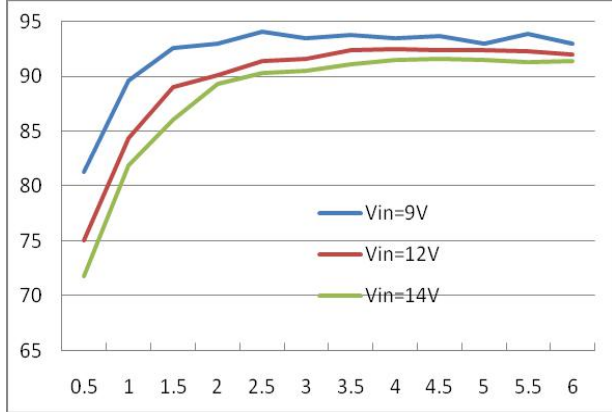

Efficiency

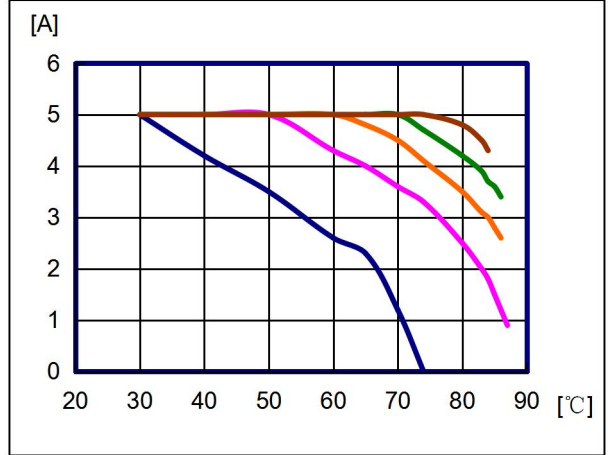

Output Current Derating (Load Current vs. Ambient Temperature (T_{REF} , See Page 6)), $V_{IN}=12V$

Recommended Hole Pattern

Dimensions are in millimeters (inches)

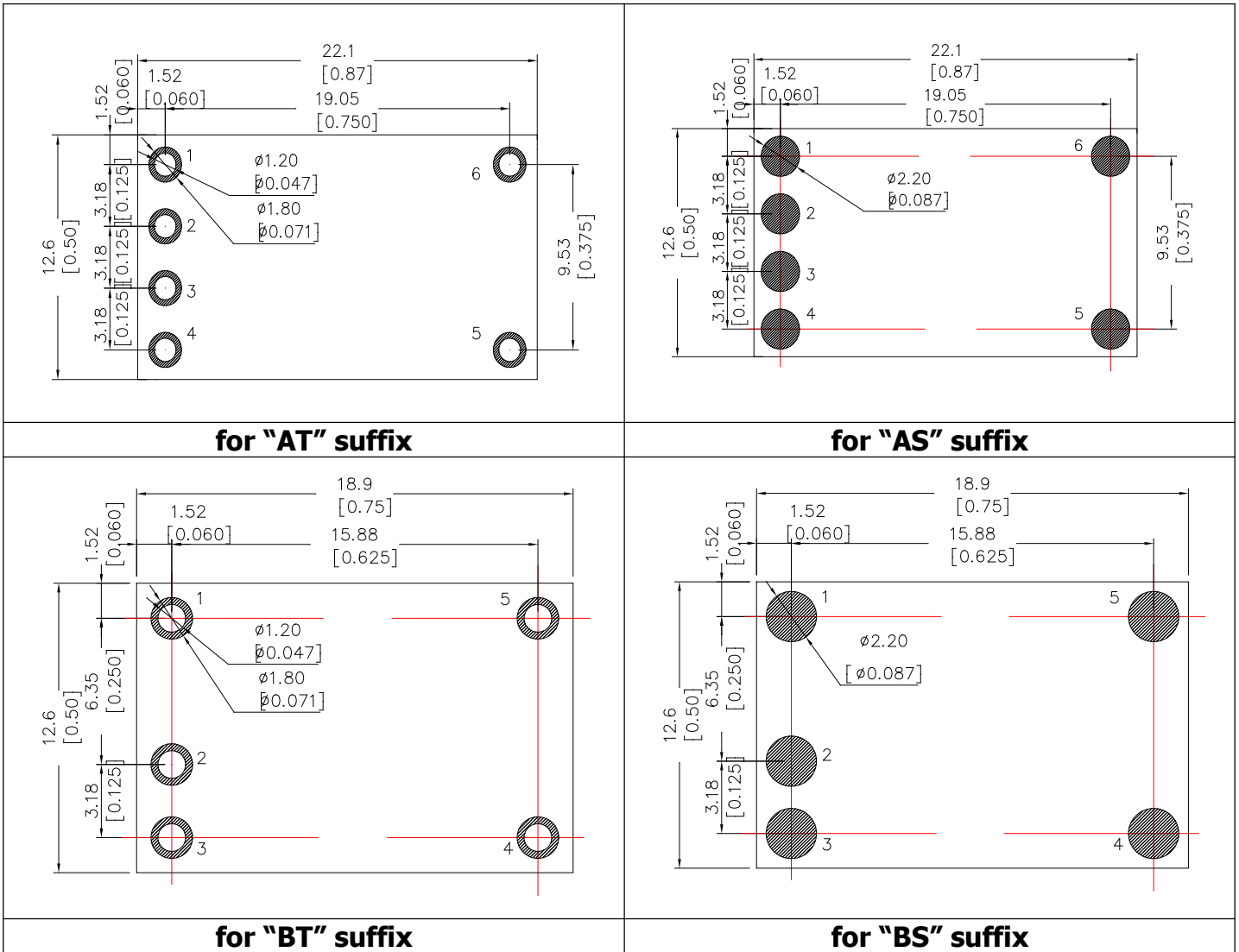

Component-side footprint

Application Notes